

## **6(b) - RF Troubleshooting Instructions**

This page has been intentionally left blank.

**Table of Contents**

	<b>Page No</b>
<b>General Information on RF Troubleshooting .....</b>	<b>5</b>
Test environment .....	5
Test conditions .....	5
<b>Receiver Verification and Troubleshooting .....</b>	<b>7</b>
General instructions for RX troubleshooting .....	7
Measuring RX I/Q signals using RSSI reading .....	7
Measuring RX performance using SNR measurement .....	8
Measuring front-end power levels using spectrum analyzer .....	10
Measuring analogue RX I/Q signals using oscilloscope .....	10
Fault finding chart of the receiver.....	11
<b>Transmitter .....</b>	<b>18</b>
General instructions for TX troubleshooting.....	18
GSM900 transmitter .....	18
General instructions for GSM TX troubleshooting .....	18
Fault finding chart for GSM900 transmitter .....	20
GSM1800 transmitter .....	22
General instructions for GSM1800 TX troubleshooting .....	22
Fault finding chart for GSM1800 transmitter .....	24
GSM1900 transmitter .....	26
General instructions for GSM1900 TX troubleshooting .....	26
Fault finding chart for GSM1900 transmitter .....	28
<b>Synthesizer .....</b>	<b>31</b>
General instructions for synthesizer troubleshooting .....	31
Checking synthesizer operation.....	31
Fault finding chart for PLL synthesizer.....	34
Frequency tables .....	36
GSM900 (including EGSM900) .....	36
GSM1800 .....	37
GSM1900 .....	39
<b>DC Supply Voltage Check .....</b>	<b>41</b>
Receiver test points .....	44
Transmitter test points .....	46
Synthesizer test points.....	49

This page has been intentionally left blank.

---

## General Information on RF Troubleshooting

---

### Notes:

*Several bills of material (BOM): There are two different kinds of VCOs, VCTXOs, RF-PAs, SAW-filters and Antenna Switches (ASM) assembled. They may only be replaced with the same type as the original component (from the same manufacturer).*

*Phoenix version: In this document there are example measurements being depicted with pictures of AMS-Phoenix, version A 2004.06.1.69. In later versions pictures of menus and windows may look differently.*

*Layout version: The drawings of test points and component placement in this version of the document are taken from build B4.0 layout (1gqa\_41a). If you use the document for newer layout versions, make sure to use the corresponding assembly and test point drawings.*

### ■ Test environment

It is assumed, that the phones are disassembled and tested with a repair jig MJ-22R.

The following measurements have to be done for repairing the phone boards:

- **RF measurements** shall be done using a spectrum analyzer together with a high-frequency probe. Note that the signal will be significantly attenuated. Correct attenuation can be checked using a “good” phone board for example.
- **LF (low frequency) and DC measurements** shall be carried out with an oscilloscope together with a 10:1 probe.
- For **receiver measurements**, a signal generator specified for frequencies up to 2000 MHz is required. The signal generator is connected to the antenna port of the repair jig.  
Most of the radio communication testers, like CMU200, can be used as a signal generator, but make sure to have a continuous (CW) signal without modulation for alignment purposes.
- **Transmitter output level measurements** shall be done with a power meter which is connected to the antenna port of the repair jig.

Always make sure that the measurement set-up is calibrated when measuring RF parameters at the antenna port. Remember to put the correct losses of the module repair jig and the connecting cable in Phoenix or in the set-up programs of the RF generators when realigning the phone.

Apart from key-components described in this document, there are a lot of discrete components (resistors, inductors and capacitors) for which troubleshooting has to be done by checking its proper soldering and complete assembly on the PWB. Capacitors and resistors can be checked by means of an ohm-meter, but be aware in-circuit measurements should be evaluated carefully.

### ■ Test conditions

**Rx tuning of the 26 MHz reference oscillator (VCTCXO) is temperature sensitive** because of the estimations of <AFC\_value> and <AFC\_slope>. According to the Production Test Specification DCS02294-EN-0.5, the ambient temperature has to be within a temperature range of 22°C to 28°C.

**Most RF semiconductors are static discharge sensitive.** ESD protection must be taken into account during repair (ground straps and ESD soldering irons).

**The RF ASIC Helgo is moisture sensitive.** Therefore, the ASIC must be pre-baked prior to soldering.

## Receiver Verification and Troubleshooting

### ■ General instructions for RX troubleshooting

Connect the phone to a PC, which has Phoenix Service Software and a dongle installed, using either

- repair jig and DAU-9S (RS232) cable or
- repair jig and XCS-4 cable via FPS-8 Flash Box or
- DAU-9T cable (RS232).

Connect the phone to a power supply (DC voltage: 3.6V, max. current: 3A) and an RF signal generator. Switch the phone on.

Start Phoenix Service Software and open FBUS connection.

Select	Scan Product	Ctrl-R
--------	--------------	--------

and wait until the phone information (RM-30) is shown in the lower right corner of the screen.

Follow the instructions below.

### ■ Measuring RX I/Q signals using RSSI reading

Start Phoenix Service Software and open FBUS connection.

Select	Scan Product	Ctrl-R
--------	--------------	--------

Wait until the phone information is shown in the lower right corner of the screen.

Set the operating mode to local mode

Select	Testing	T
--------	---------	---

RF Controls	F
-------------	---

Select	Band	GSM 900 or GSM1800 or GSM1900
--------	------	-------------------------------

Active unit	RX
-------------	----

Operation mode	Burst
----------------	-------

RX/TX Channel	37 or 700 or 661
---------------	------------------

Select	Testing	T
--------	---------	---

<u>RSSI reading</u>	R
---------------------	---

In the RSSI Reading window, the <measuring mode> shall be set on **Sum vector** and the <reading mode> on **Continuous**.

The set up should now look like this:

(The example below shows a screen shot in GSM900!)

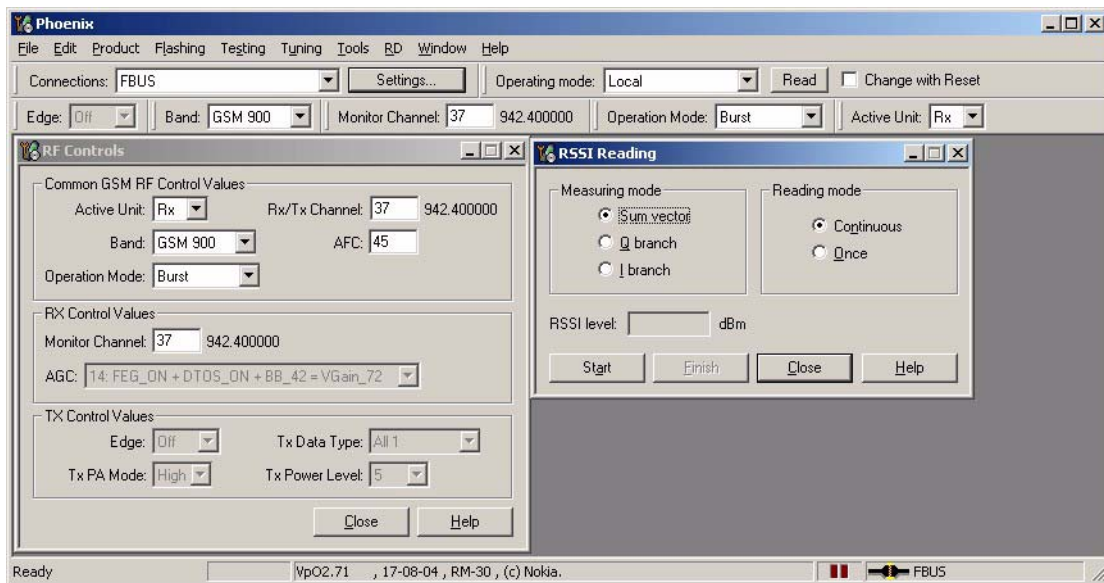

Make the following settings on your signal generator:

Frequencies:

- GSM 900: 942.46771 MHz (channel 37+ 67.710 kHz offset)
- GSM 1800: 842.86771 MHz (channel 700 + 67.710 kHz offset)
- GSM 1900: 1960.06771 MHz (channel 661+ 67.710 kHz offset)

RF power level:

- – 80 dBm @ the antenna connector of the phone/ test jig (remembering to compensate for the cable and jig attenuation).

Click on <Read now> in RSSI reading.

The resulting RSSI level shall be – 80 dBm +/- 0.5 dB in each band.

### *Measuring RX performance using SNR measurement*

Start Phoenix Service Software and open FBUS connection.

Select Scan Product Ctrl-R

Wait until the phone information is shown in the lower right corner of the screen.

Set operating mode to <local mode>.

Select Testing T

RF Controls F

Select Band GSM 900 or GSM1800 or GSM1900

Active unit RX



	Operation mode	<b>Burst</b>	
	RX/TX Channel	37 or 700 or 661	
Select	Testing		T
		SNR Measurement	M
Select	Measuring mode	Fast SNR (Radio Button)	
Press	Start		

The window <Signal Measurement> pops up informing on **frequency** and **power level** of the signal generator to be set. Follow the command <Turn ON the RF generator>.

Press <ok> and the window will close.

Read the SNR result from the window SNR Measurement. The value shall exceed:

- GSM 900: > 20 dB
- GSM 1800: > 18 dB
- GSM 1900: > 18 dB

The set up should now look like this:

(The example below shows a screen shot in GSM900!)

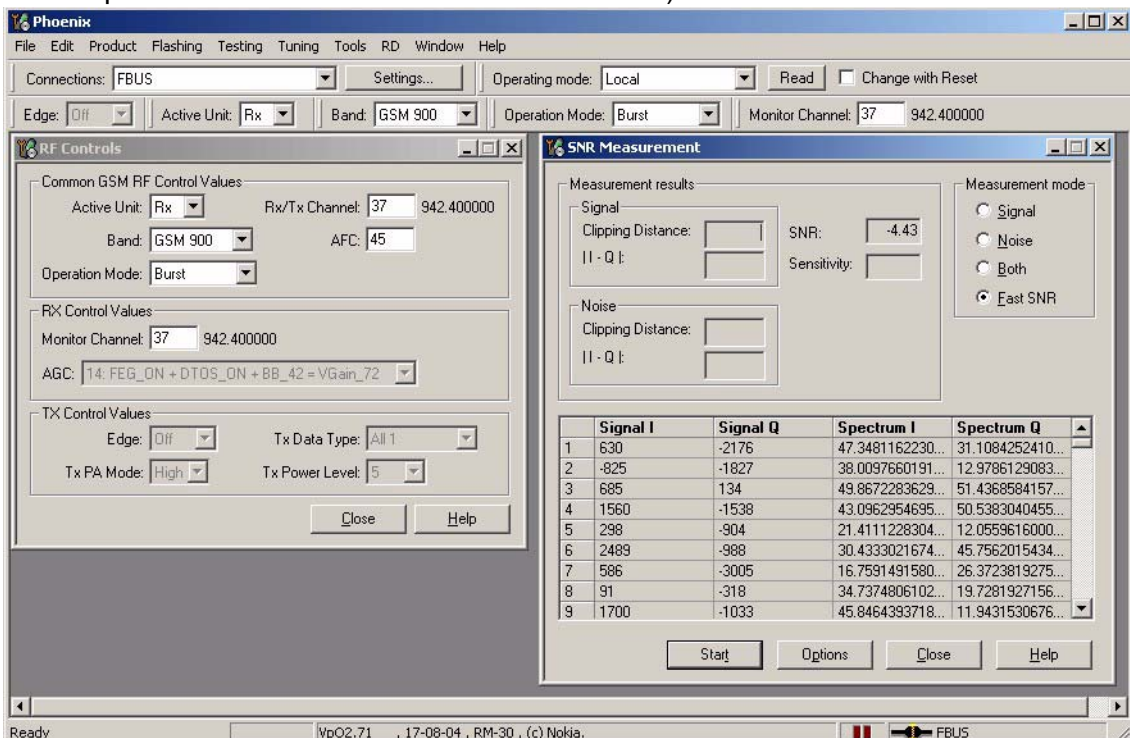

Choose the remaining GSM bands and measure accordingly the procedure described above.

*Measuring front-end power levels using spectrum analyzer*

Spectrum analyzer (SA) level values depend on the probe type and shall be verified by a properly working phone sample. The levels that are given in this document are measured with a resistive probe (50 Ohm semi-rigid cable).

Start Phoenix Service Software and open FBUS connection.

Select	Scan Product	Ctrl-R
--------	--------------	--------

Wait until the phone information is shown in the lower right corner of the screen.

Set <operating mode> to <local mode>.

Select	Testing	T
	RF Controls	F
Select	Band	GSM 900 or GSM1800 or GSM1900
	Active unit	RX
	Operation mode	Continuous
	RX/TX Channel	37 or 700 or 661

Please refer to the fault finding chart and Appendix for proper levels at different test points.

*Measuring analogue RX I/Q signals using oscilloscope*

Measuring with an oscilloscope RX I and RX Q signals on the test points <RXI> respectively <RXQ> is recommended only if the RSSI reading does not provide enough information. Input level = -60dBm.

Start Phoenix Service Software and open FBUS connection.

Select	Scan Product	Ctrl-R
--------	--------------	--------

Wait until phone information is shown in the lower right corner of the screen.

Set operating mode to <local mode>.

Select	Testing	T
	RF Controls	F

Wait until the RF Controls window pops up.

Select	Band	GSM 900 or GSM1800 or GSM1900
	Active unit	RX
	Operation mode	Continuous
	RX/TX Channel	37 or 700 or 661
	AGC	10

The following picture should be displayed on an oscilloscope's screen if the receiver is working properly:

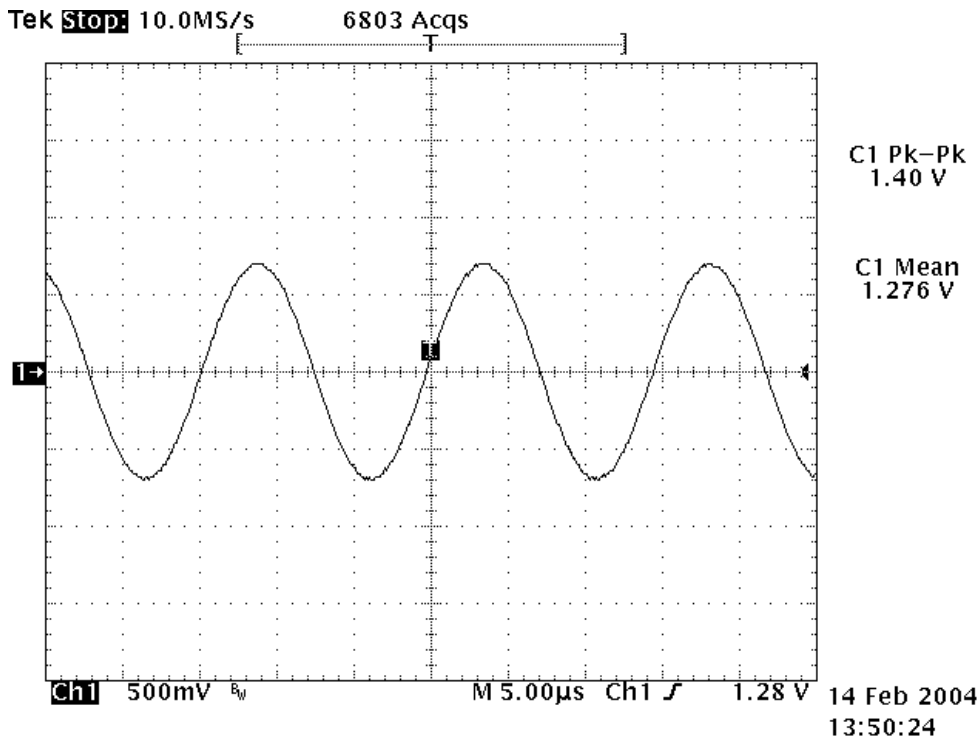

Signal amplitude 1.40Vpp

DC offset <sup>a</sup> 1.28V as the offset is floating, switch to the operating mode <Burst> in Phoenix and read the DC offset

Frequency 67kHz

### ■ Fault finding chart of the receiver

During fault finding, the calibration procedure is used to find out, whether all bands are affected (error in common part of the Rx chain) or only one band (error in a Rx part of the failed band). **Take care not to save calibration values to the phone memory, which are out of limits. Find the error first and repair it.**

When a defective phone has been calibrated, a possible error in RX front-end might be masked. In that case, one can get a reasonable RSSI reading, although the front-end shows excessive losses. If it is not sure that incorrect re-calibration has been made, following steps shall be carried out:

- Check if AGC calibration is within limits.
- Check if SNR reading is o.k.

Use an oscilloscope to check levels of "RXI" and "RXQ".

The RF ASIC generates only single ended I and Q signals (RXI, RXQ). As the A/D converter in UEM requires two differential signals, an artificial mid voltage is generated from VrefRF02. The phone layout has dedicated test points for the analogue RX I and Q signals (J512, J513).

The BB part is used to measure those signals by means of RSSI reading. This works only if correct calibration has been carried out in production.

$$\text{RSSIreading [dBm]} = 20\log(U_{\text{BB}}/U_{\text{LSB}}) - \text{AGC}_{\text{calibrated}}$$

In order to check the levels and frequencies of RF signals, the following probe can be used (note that only the core lead contacts the test point, the shielding of the coaxial cable does not contact GND during the measurement):



Connect this probe via a coaxial cable and a DC block to a spectrum analyzer. The **DC block is important** to protect the spectrum analyzer from DC levels, which superpose the RF signal at several test points.

If both RX *and* TX path seem to be faulty, it has to be checked if the synthesizer is working.

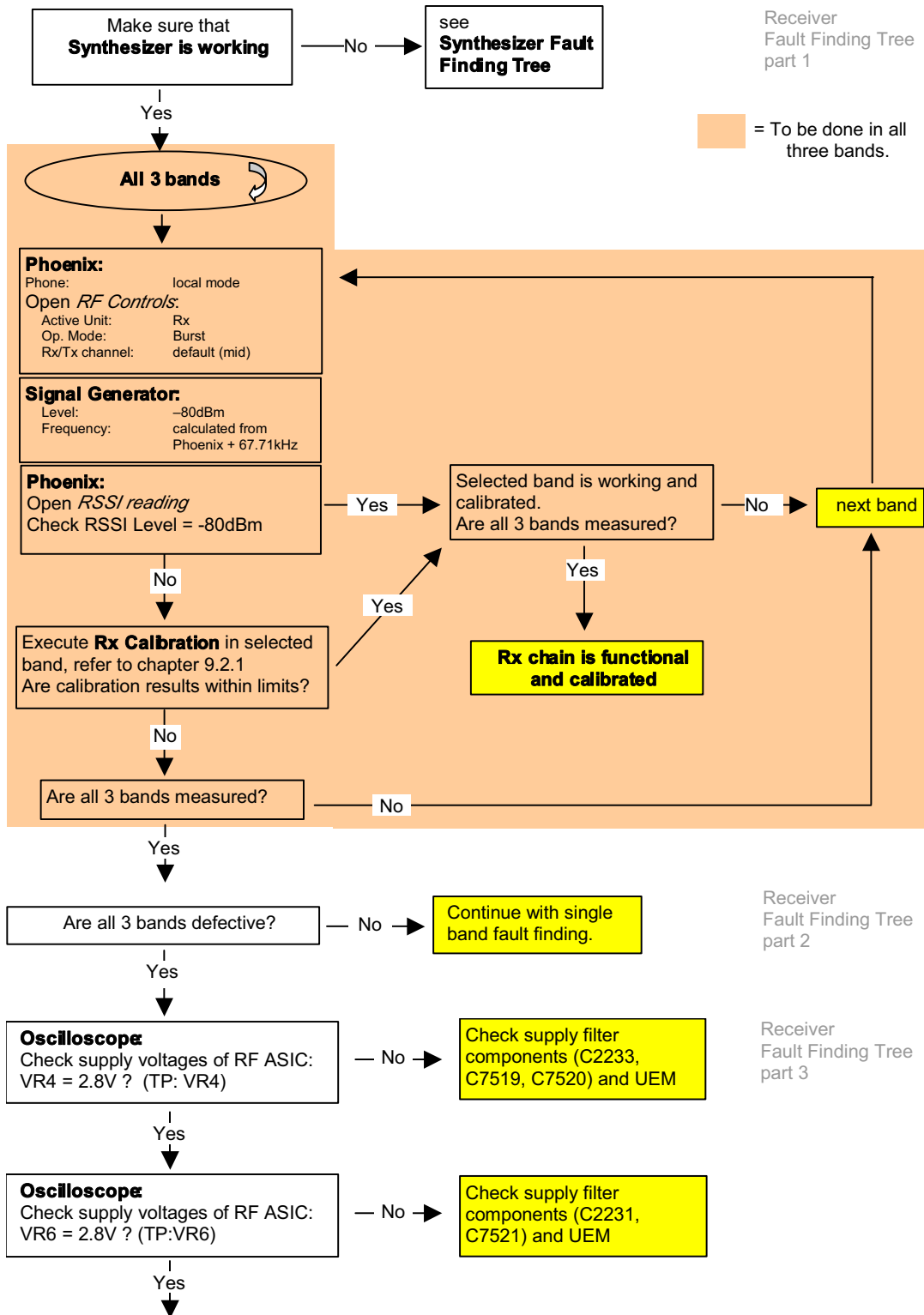

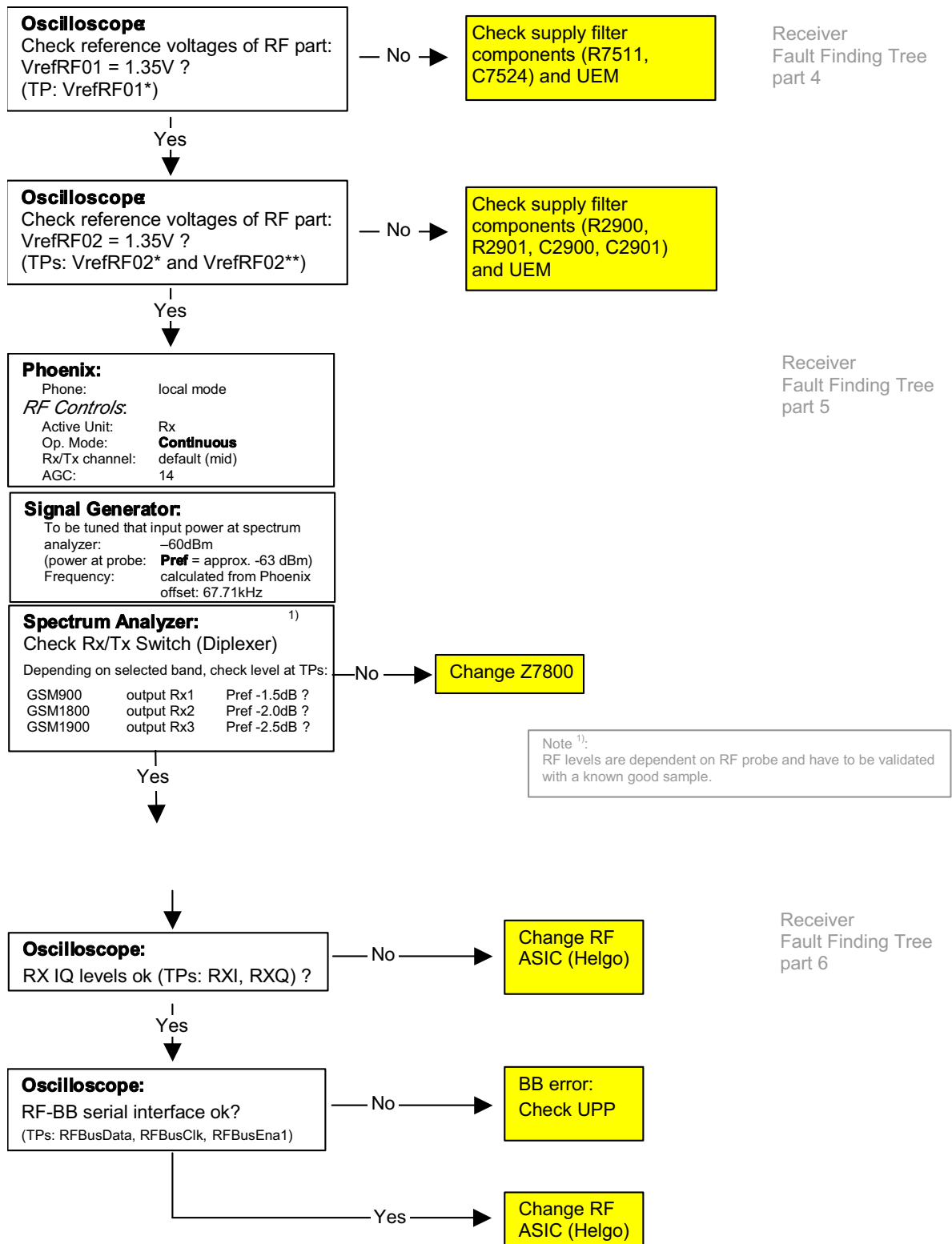

**Single band fault finding**  
Select faulty band in Phoenix and continue measurements on dedicated Rx part.

Receiver  
Fault Finding Tree  
part 7

**Phoenix:**  
open *SNR Measurement*  
Meas. Mode: Fast SNR  
Press *Measure*.

**Signal Generator:**  
Level: -92dBm  
Frequency: calculated from Phoenix

**Phoenix:**  
SNR measurement ok?  
(SNR > 18.37dB)?

Yes →

Front end is ok.

**Phoenix:**  
Phone: local mode  
*RF Controls:*  
Active Unit: Rx  
Op. Mode: **Continuous**  
Rx/Tx channel: default (mid)  
AGC: 10

**Signal Generator:**  
Level: -60dBm  
Frequency: calculated from Phoenix  
offset: 67.71kHz

Continue with Rx Fault Finding part 6.

No

**Phoenix:**  
Phone: local mode  
*RF Controls:*  
Active Unit: Rx  
Op. Mode: **Continuous**  
Rx/Tx channel: default (mid)  
AGC: 14

**Signal Generator:**  
To be tuned that input power at spectrum analyser:  
-60dBm  
power at probe: **Pref** = approx. -63dBm  
Frequency: calculated from Phoenix  
offset: 67.71kHz

**Spectrum Analyzer:**<sup>1)</sup>  
Center Freq: calculated from Phoenix  
RBW: 20kHz

Check Rx SAW filter and matching network of selected band:  
GSM900 TPs: INM\_G\_RX / INP\_G\_RX  
both output levels > Pref -3.5dB ?  
GSM1800 TPs: INM\_D\_RX / INP\_D\_RX  
both output levels > Pref -6dB ?

No →

Change Rx SAW filters (Z7802, Z7803) or component(s) of matching network depending on selected band

Yes

Receiver  
Fault Finding Tree  
part 8

Note 1):  
RF levels are dependent on RF probe and have to be validated with a known good sample.

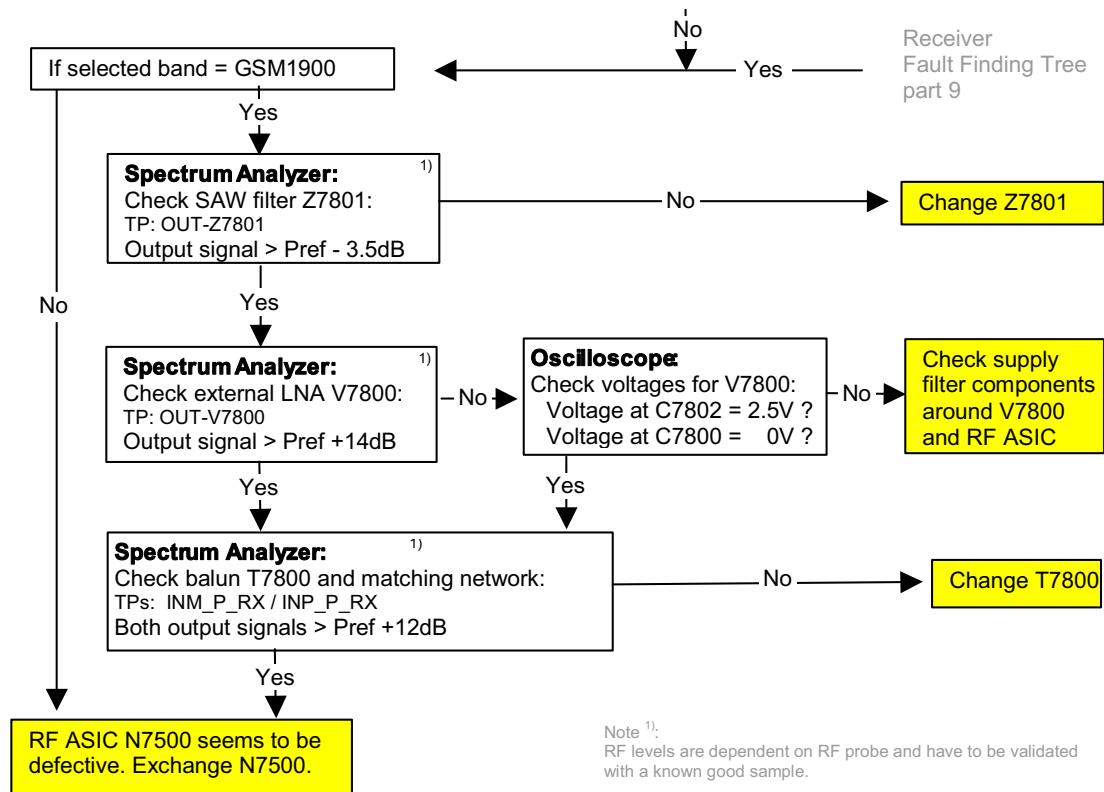



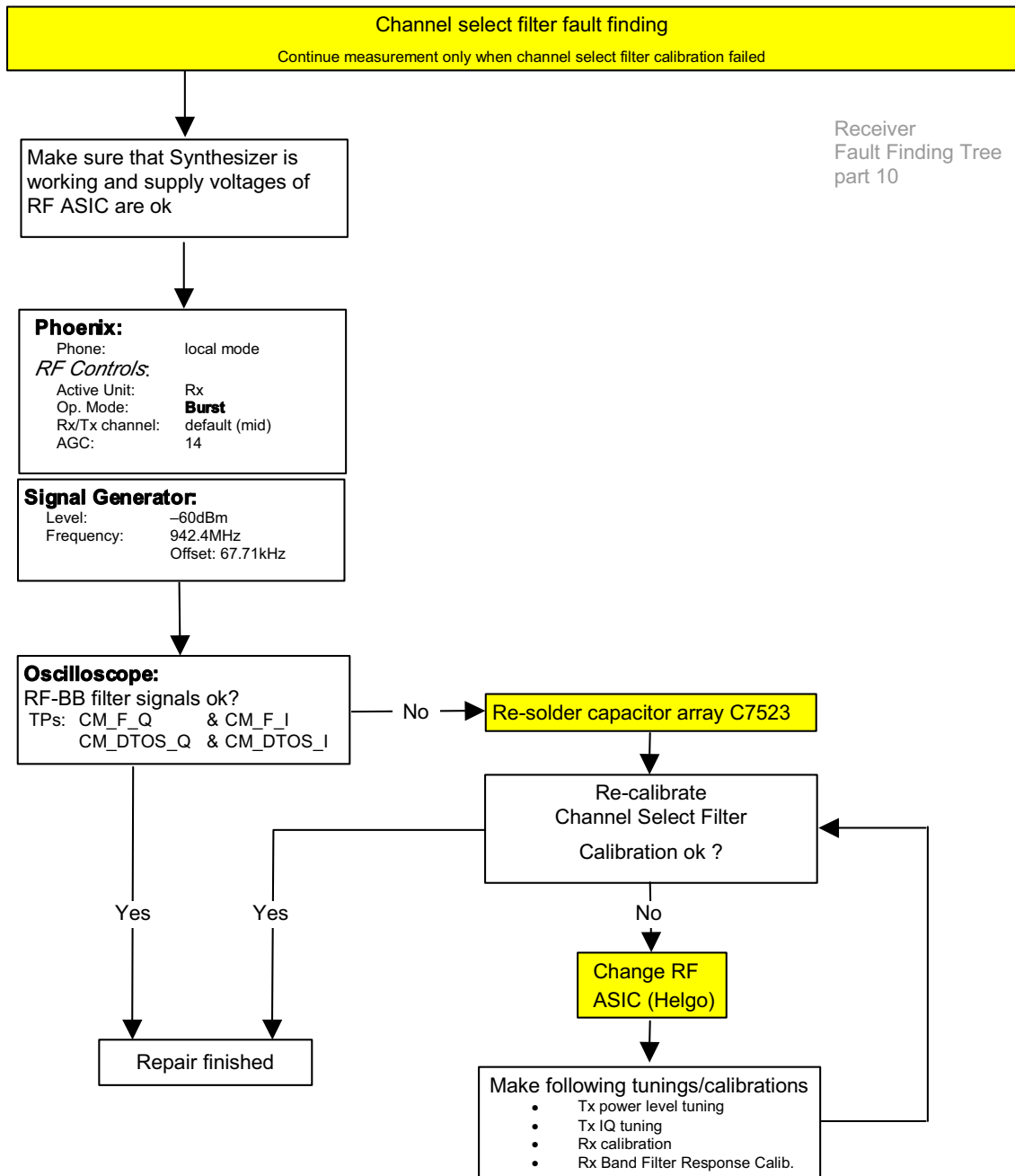

## Transmitter

### ■ General instructions for TX troubleshooting

Connect the phone to a PC, which has Phoenix Service Software and a dongle installed, using either

- repair jig and DAU-9S (RS232) cable or
- repair jig and XCS-4 cable via FPS-8 Flash Box or
- DAU-9T cable (RS232)

Connect the phone to a power supply (DC voltage of **3.6V**) and switch the phone on. The value of the DC voltage of 3.6V at the phone battery connector is crucial.

Connect an RF cable between the test jig and the measurement equipment (GSM test equipment, power meter, spectrum analyzer, or similar).

Make use of an adequate attenuator at the input of your measurement equipment (10dB to 20dB are recommended for a spectrum analyzer or a power meter). Additionally, a DC block is recommended. Assure not to overload or destroy the equipment.

It is strongly recommended to use TXP as external trigger for all TX tunings. External triggering gives the following advantages:

- trigger for spectrum analyzer (gated sweep)
- trigger for oscilloscope
- trigger for power meter (avoid exchanging of attenuator and getting better accuracy in power measurements)

Start Phoenix Service Software and open FBUS connection:

Select      Scan Product                      Ctrl-R

and wait until the phone information is shown in the lower right corner of the screen.

Follow the instructions in the chapters below.

### ■ GSM900 transmitter

The GSM900 chapters apply only for RM-30 (EU variant).

#### *General instructions for GSM TX troubleshooting*

Start the preparations as described in chapter "General instructions for TX troubleshooting".

#### **GMSK**

Set operating mode to local mode.

Select      Testing                                      RF Controls

Wait until the RF Controls window pops up

Select      Band    GSM 900

Active unit	TX
Operation mode	Burst
RX/TX Channel	37
TX Power Level	10
TX Data Type	Random
Edge	Off

The setup should now look like this:

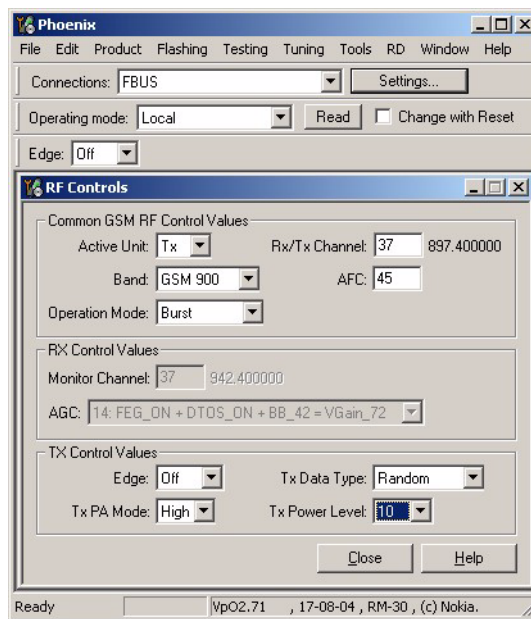

Now the measurement equipment should detect the following output signal of the phone:

$$P_{out} = +23dBm @ 897.4 MHz$$

If this is not the case, go to the GMSK fault finding chart for the GSM900 transmitter.

**EDGE**

Set operating mode to local mode.

Select	Testing	RF Controls
--------	---------	-------------

Wait until the RF Controls window pops up.

Select	Band	GSM 900
	Active unit	TX
	Operation mode	Burst
	RX/TX Channel	37

TX Power Level	10
TX Data Type	All1
Edge	On

The setup should now look like this:

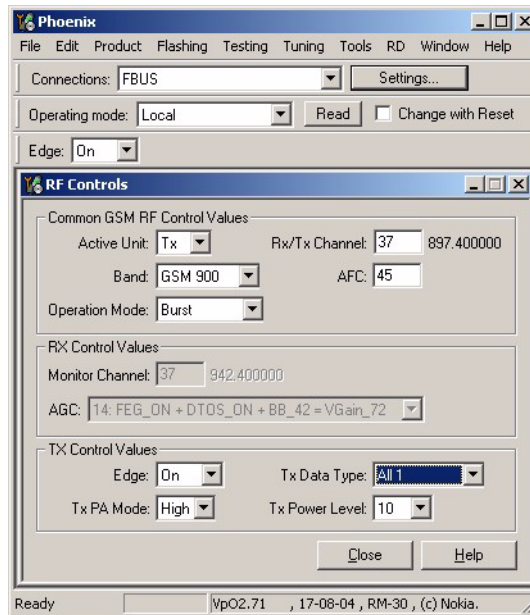

Now the measurement equipment should detect the following output signal of the phone:

$$P_{out} = +24.5 \text{ dBm @ } 897.4 \text{ MHz}$$

If this is not the case, go to the EDGE fault finding chart for GSM900 transmitter.

*Fault finding chart for GSM900 transmitter*

In the following, it is assumed that the TXP signal is used as trigger signal. For that, a TXP test point is provided.

**GMSK**

Use Phoenix to select  
TX\_Data Type: Random  
TX Power Level: 10  
Ch37  
Ensure Vbatt=3.6 V

Yes

Oscilloscope	Mode	V = 0 Volt
C7711		
R7511	VREF01	Vdc = 1.35 Volt
C7512	VR2	Vdc = 2.78 Volt
TXP testpoint	TXP	V = 1.8 Volt
C7517	VR5	Vdc = 2.78 Volt
R7516	VR3	Vdc = 2.78 Volt

No

Check Baseband

Yes

Oscilloscope		
C7529	TXIOUTP	67kHz Vac = 0.45 Vpp, Vdc = 1.2 V
C7529	TXIOUTN	67kHz Vac = 0.45 Vpp, Vdc = 1.2 V
C7530	TXQOUTP	67kHz Vac = 0.45 Vpp, Vdc = 1.2 V
C7530	TXQOUTN	67kHz Vac = 0.45 Vpp, Vdc = 1.2 V

No

Check Baseband

Yes

Oscilloscope		
C7701	VTXB_900	V = 2.78 Volt
VC1	CONT1	V = 0 Volt
VC2	CONT2	V = 0 Volt
VC3	CONT3	V = 2.7 Volt
R7713	VPCTRL_900	V = 1.17 Volt

No

Check: Helgo Serial Interface Helgo

Yes

Spectrum analyzer		
Z7700 out, R7704 in	RFin_850/900	P >= 2 dBm, 897.4MHz Compare with good sample

No

Check EGSM TX SAW Filter  
Helgo  
Synthesizer

Yes

Spectrum analyzer  
Z7800 TX1 (PA N7700  
RFOut\_850/900)  
Power = +24.3 dBm,  
897.4 MHz

No

Check PA N7700  
Check Power Loop  
(Txc, Vpctrl900, DET)

Yes

Spectrum analyzer  
RF@Test-Jig  
Pout = +23 dBm, 897.4 MHz

No

Check Antenna Switch (Z7800)

Yes

GSM900 TX  
OK

**EDGE**

Ensure that GMSK is ok.

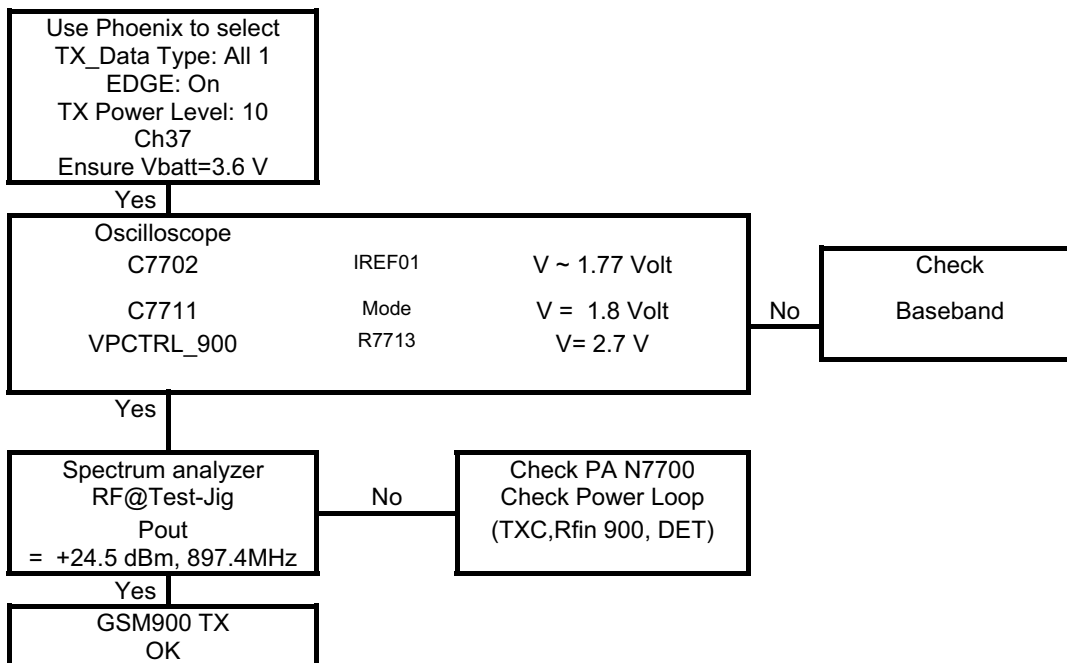

■ **GSM1800 transmitter**

*General instructions for GSM1800 TX troubleshooting*

Start the preparations as described in chapter “General instructions for TX troubleshooting”.

**GMSK**

Set operating mode to local mode.

Select	Testing	RF Controls
--------	---------	-------------

Wait until the RF Controls window pops up

Select	Band	GSM 1800
	Active unit	TX
	Operation mode	Burst
	RX/TX Channel	700
	TX Power Level	5
	TX Data Type	Random
	Edge	Off

The setup should now look like this:

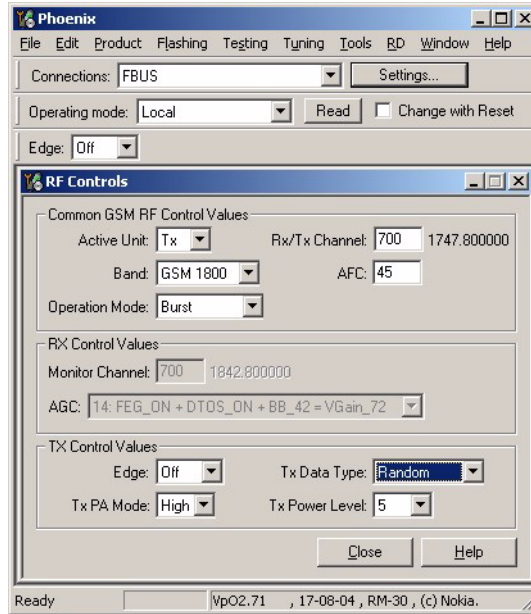

Now the measurement equipment should detect the following output signal of the phone:

$$P_{out} = +23dBm @ 1747.8 MHz$$

If this is not the case, then go to the GMSK fault finding chart for GSM1800 transmitter.

**EDGE**

Set operating mode to local mode.

Select      Testing                      RF Controls

Wait until the RF controls window pops up.

Select      Band                      GSM 1800

Active unit                      TX

Operation mode                      Burst

RX/TX Channel                      700

TX Power Level                      5

TX Data Type                      All 1

Edge                      On

The setup should now look like this:

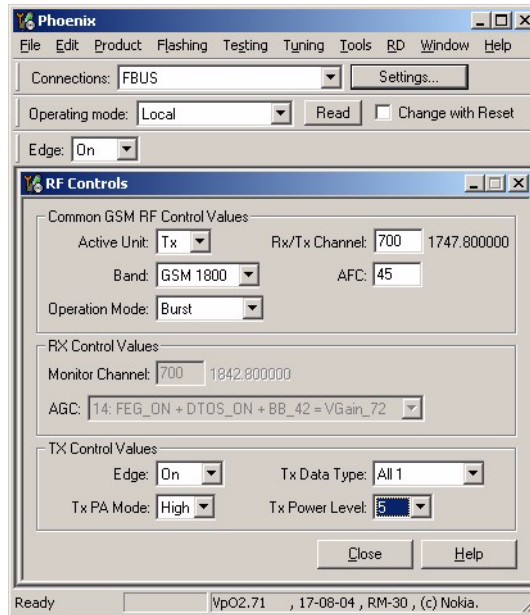

Now the measurement equipment should detect the following output signal of the phone:

$$P_{\text{out}} = +21.5 \text{ dBm @ } 1747.8 \text{ MHz}$$

If this is not the case, then go to the EDGE fault finding chart for GSM1800 transmitter.

#### *Fault finding chart for GSM1800 transmitter*

In the following, it is assumed that the TXP signal is used as trigger signal. For that, a TXP test point is provided.



**GMSK**

TX\_Data Type: Random  
 TX Power Level: 5  
 Ch700  
 Ensure Vbatt=3.6 V

Yes

Oscilloscope	Mode	V = 0 Volt
C7711	VREF01	Vdc = 1.35 Volt
R7511	VR2	Vdc = 2.78 Volt
C7512	TXP	V = 1.8 Volt
TXP testpoint	VR5	Vdc = 2.78 Volt
C7517	VR3	Vdc = 2.78 Volt
R7516		

No

Check Baseband

Yes

Oscilloscope		
C7529	TXIOUTP	Vac = 0.4 Vpp, Vdc = 1.2 V
C7529	TXIOUTN	Vac = 0.4 Vpp, Vdc = 1.2 V
C7530	TXQOUTP	Vac = 0.4 Vpp, Vdc = 1.2 V
C7530	TXQOUTN	Vac = 0.4 Vpp, Vdc = 1.2 V

No

Check Baseband

Yes

Oscilloscope		
C7709	VTXB_1800_1900	V = 2.7 Volt
VC1	CONT1	V = 2.7 Volt
VC2	CONT2	V = 2.7 Volt
VC3	CONT3	V = 0 Volt
R7715	VPCTRL_1800_1900	V > 1.14 Volt

No

Check Helgo Serial Interface Helgo

Yes

Spectrum analyzer		
T7700 out, R7709 in	RFin_1800/1900	P > 2 dBm, 1747.8MHz
		Compare with good sample

No

Check T7700 Balun Helgo Synthesizer

Yes

Spectrum analyzer  
 Z7800 TX2 (PA N7700  
 RFOut\_1800/1900)  
 Power = +21.6 dBm,  
 1747.8 MHz

No

Check PA N7700  
 Check Power Loop  
 (TXC, Vpctrl 1800 1900, DET)

Yes

Spectrum analyzer  
 RF@Test-Jig  
 Pout = +20 dBm, 1747.8 MHz

No

Check Antenna Switch (Z7800)

Yes

GSM 1800 TX  
 OK

**EDGE**

Ensure that GMSK is ok.

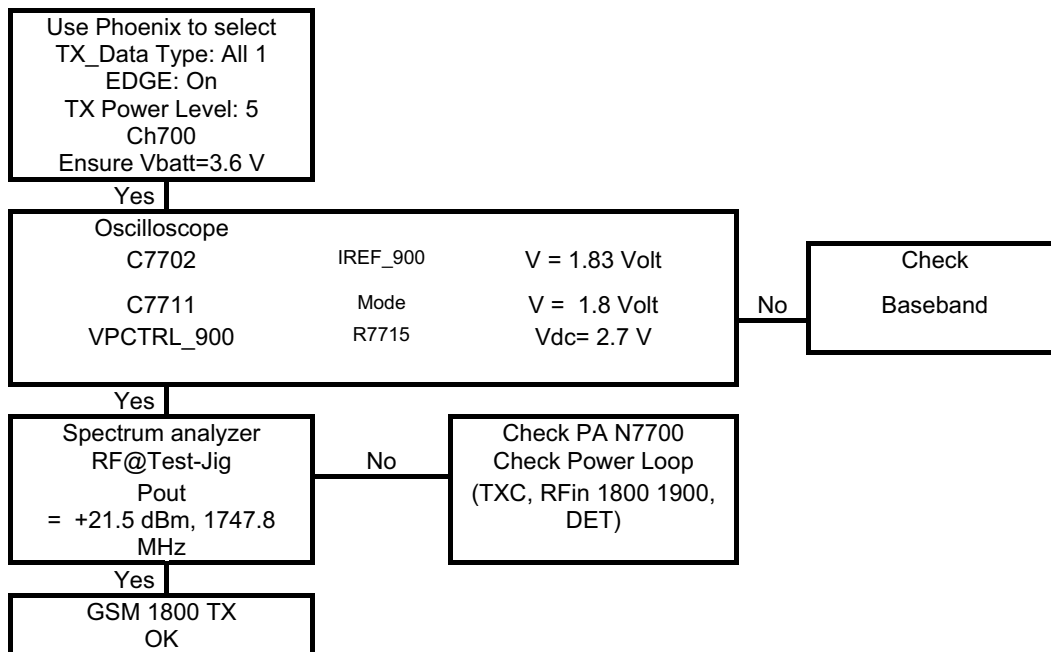

■ **GSM1900 transmitter**

*General instructions for GSM1900 TX troubleshooting*

Start the preparations as described in chapter “General instructions for TX troubleshooting”.

**GMSK**

Set operating mode to local mode.

Select	Testing	RF Controls
--------	---------	-------------

Wait until the RF Controls window pops up.

Select	Band	GSM 1900
	Active unit	TX
	Operation mode	Burst
	RX/TX Channel	661
	TX Power Level	5
	TX Data Type	Random
	Edge	Off

The setup should now look like this:

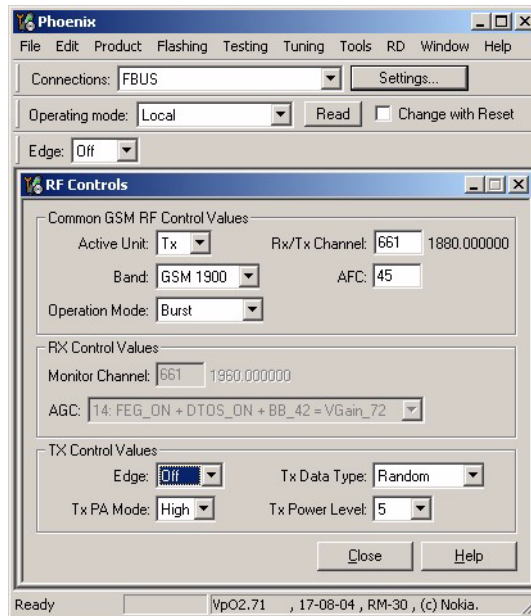

Now the measurement equipment should detect the following output signal of the phone:

$$P_{out} = +23dBm @ 1880 MHz$$

If this is not the case, then go to the GSMK fault finding chart for GSM1900 transmitter.

**EDGE**

Set operating mode to local mode.

Select	Testing	RF Controls
--------	---------	-------------

Wait until the RF Controls window pops up.

Select	Band	GSM 1900
--------	------	----------

Active unit	TX
-------------	----

Operation mode	Burst
----------------	-------

RX/TX Channel	661
---------------	-----

TX Power Level	5
----------------	---

TX Data Type	All1
--------------	------

Edge	On
------	----

The setup should now look like this:

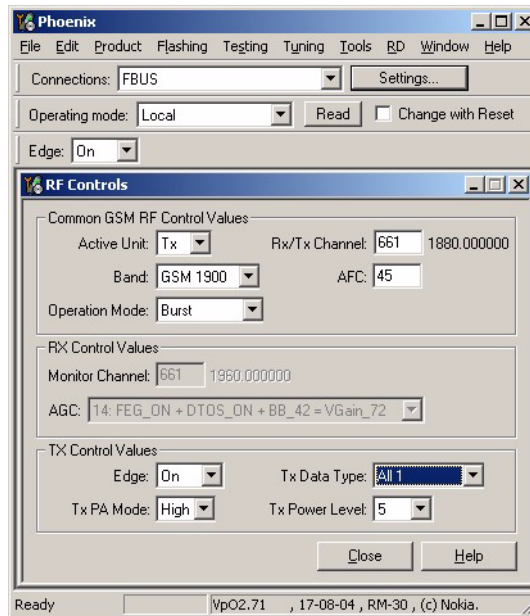

Now the measurement equipment should detect the following output signal of the phone:

$$P_{\text{out}} = +21.5 \text{ dBm @ } 1880 \text{ MHz}$$

If this is not the case, then go to the EDGE fault finding chart for GSM1900 transmitter.

#### *Fault finding chart for GSM1900 transmitter*

In the following, it is assumed that the TXP signal is used as trigger signal. For that, a TXP test point is provided.

**GMSK**

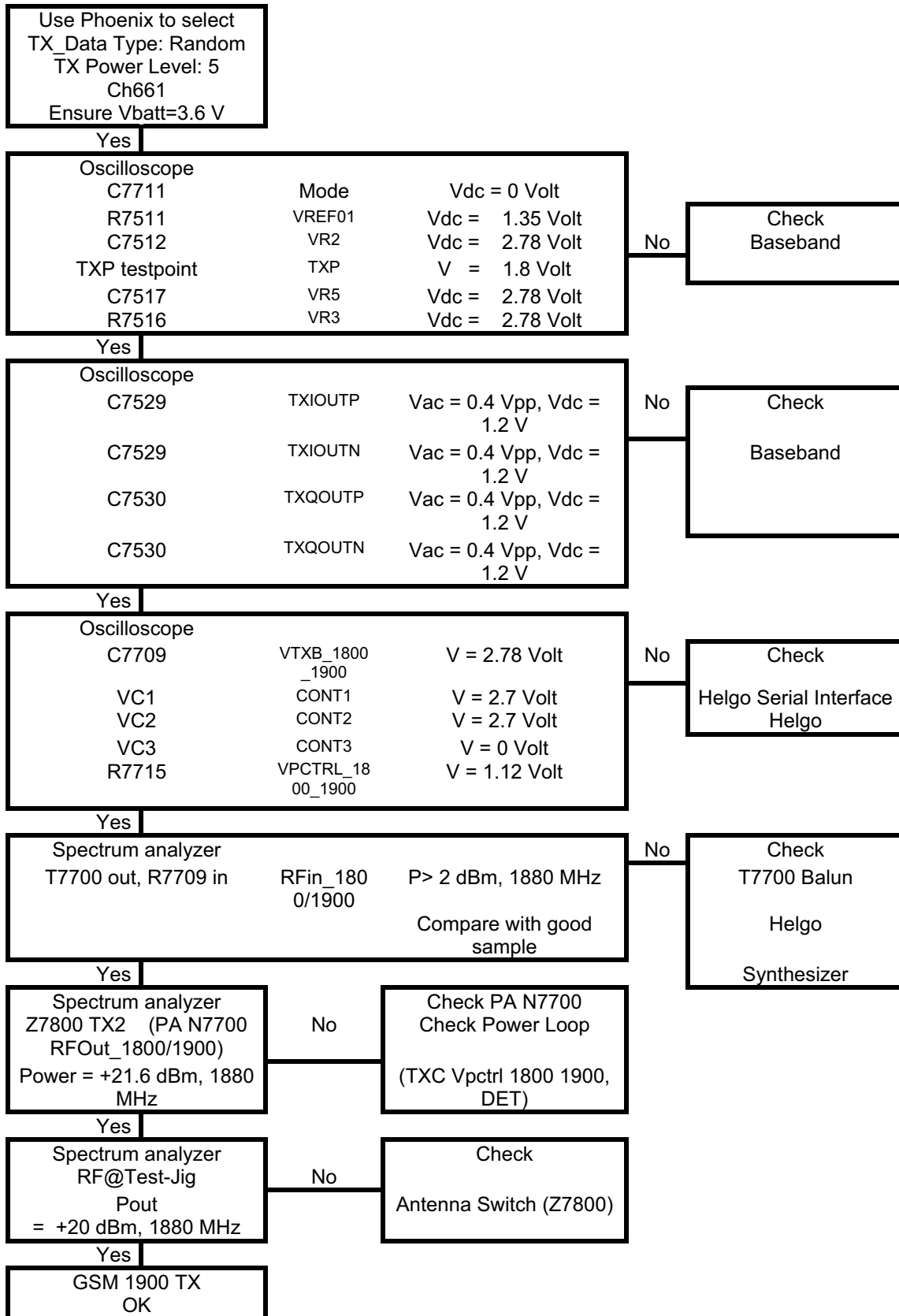

**EDGE**

Ensure that GSMK is ok.

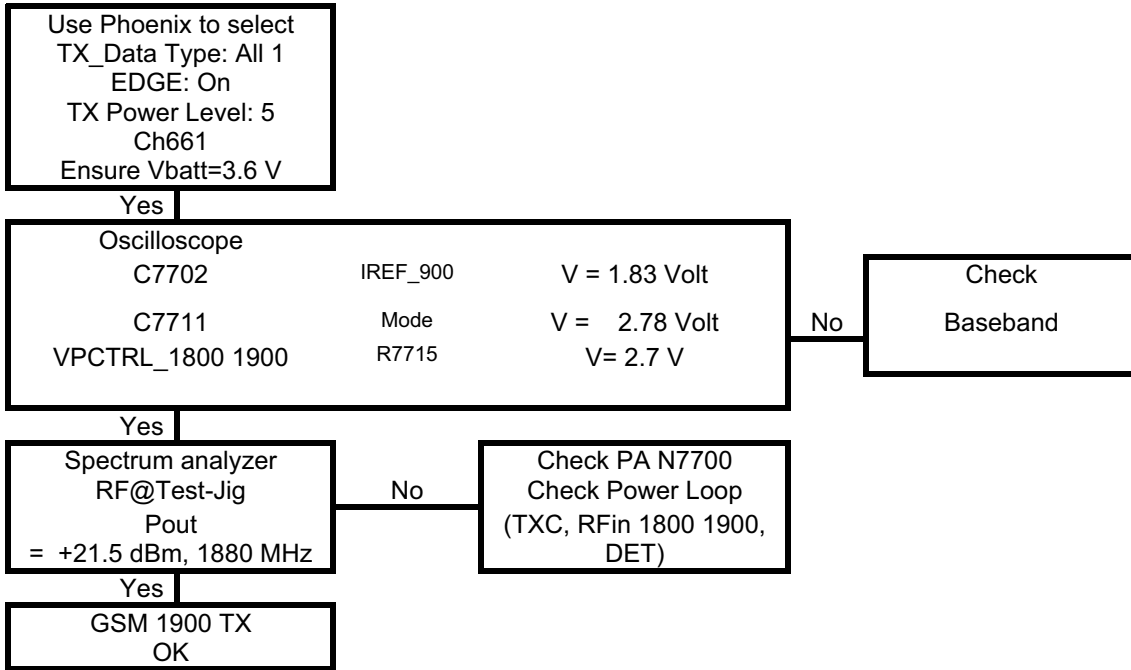

## Synthesizer

### ■ General instructions for synthesizer troubleshooting

Connect the phone to a PC, which has Phoenix Service Software and a dongle installed, using either

- repair jig and DAU-9S (RS232) cable or
- repair jig and XCS-4 cable via FPS-8 Flash Box or
- DAU-9T cable (RS232).

Connect the phone to a power supply (DC voltage of 3.6V) and switch the phone on.

Follow the instructions in the chapters below.

### ■ Checking synthesizer operation

Start Phoenix Service Software and open FBUS connection.

Select "Scan Product" (Ctrl-R or in menu File - Scan Product).

Wait until phone information is shown in the lower right corner of the screen.

Set <operating mode> to <Local>.

Open window "RF Controls" (menu Testing - RF Controls)

Set the synthesizer to the following mode:

Select	Band	GSM 1800
	Active unit	RX
	Operation mode	Continuous
	RX/TX Channel	700

The setup should now look like this:

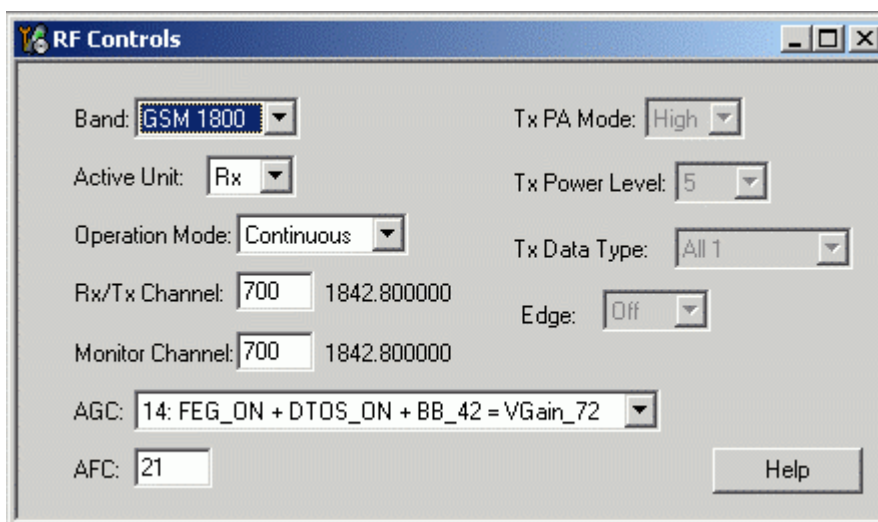

The VCO chamber has a fixed shielding lid, which can only be opened by destroying it. To enable measurements with a closed lid, holes are located at positions where the supply voltage VR7, the tuning voltage Vc and the output frequency  $f_{VCO}$  can be measured.

**Figure 1: Test holes in the VCO chamber**

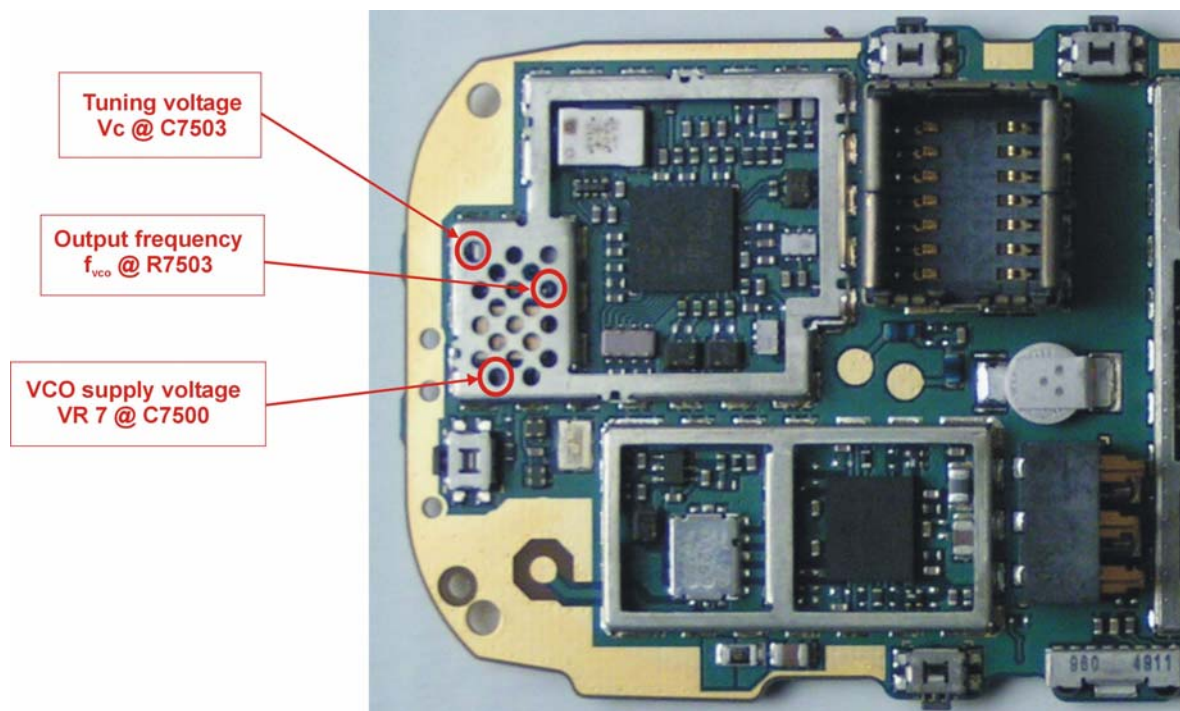

The VCO frequency has to be measured with a special probe, which fits into the holes of the shielding lid. A thin coax cable can be used for this purpose, where the outer conductor is removed for 2mm. The isolation and the inner conductor must fit into the hole of the shielding lid and provide a capacitive coupling to the attenuator R7503 at the VCO output. A spectrum analyzer is used to display the frequency.

**Figure 2: VCO probe**



The VCO frequency is twice the Rx frequency in the GSM1800 band:

$$f_{VCO} = 2 * f_{RX} = 2 * 1842.8 \text{ MHz} = \mathbf{3685.6 \text{ MHz}}$$

The tuning voltage can be easily measured at the Vc input of the VCO. The corresponding hole in the shielding lid enables the voltage measurement at C7503, which shows the same DC voltage as Vc.

The tuning voltage should be **2.1V<sub>DC</sub> .. 2.6V<sub>DC</sub>** at  $f_{VCO} = 3685.6\text{MHz}$ .

The tuning sensitivity of the VCO is typically 250MHz/V. The typical relation of VCO frequency and tuning voltage is shown in the following diagram:



**Figure 3: Typical frequency tuning curve for the FDK VCO**

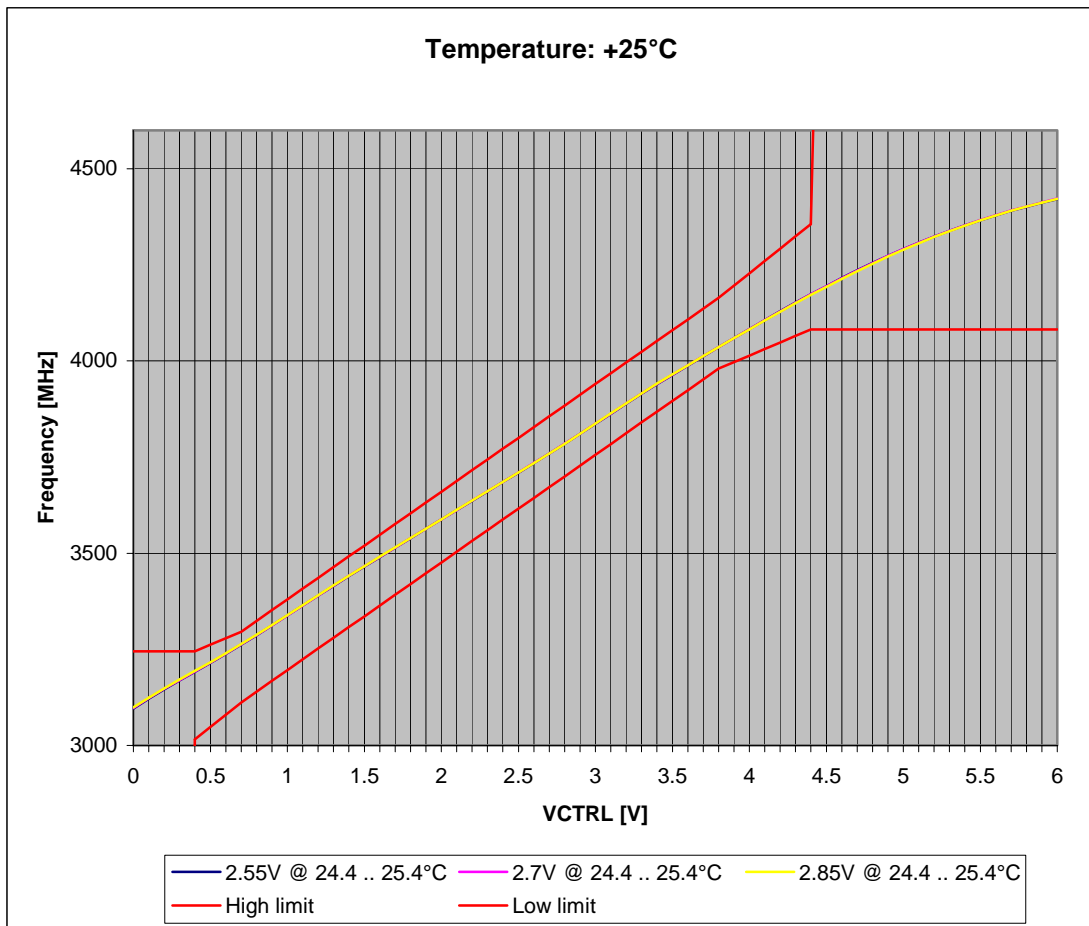

Even if the PLL is not working properly (Vc outside the valid range), a frequency at the output of the VCO can be detected between 3GHz and 4.4 GHz (if the VCO itself is ok and the supply voltage VR7 = 2.78V is applied).

If the frequency or the tuning voltage have other values than given above, see the fault finding chart for PLL synthesizer below.

■ **Fault finding chart for PLL synthesizer**

**Figure 4:PLL Fault Finding Tree**

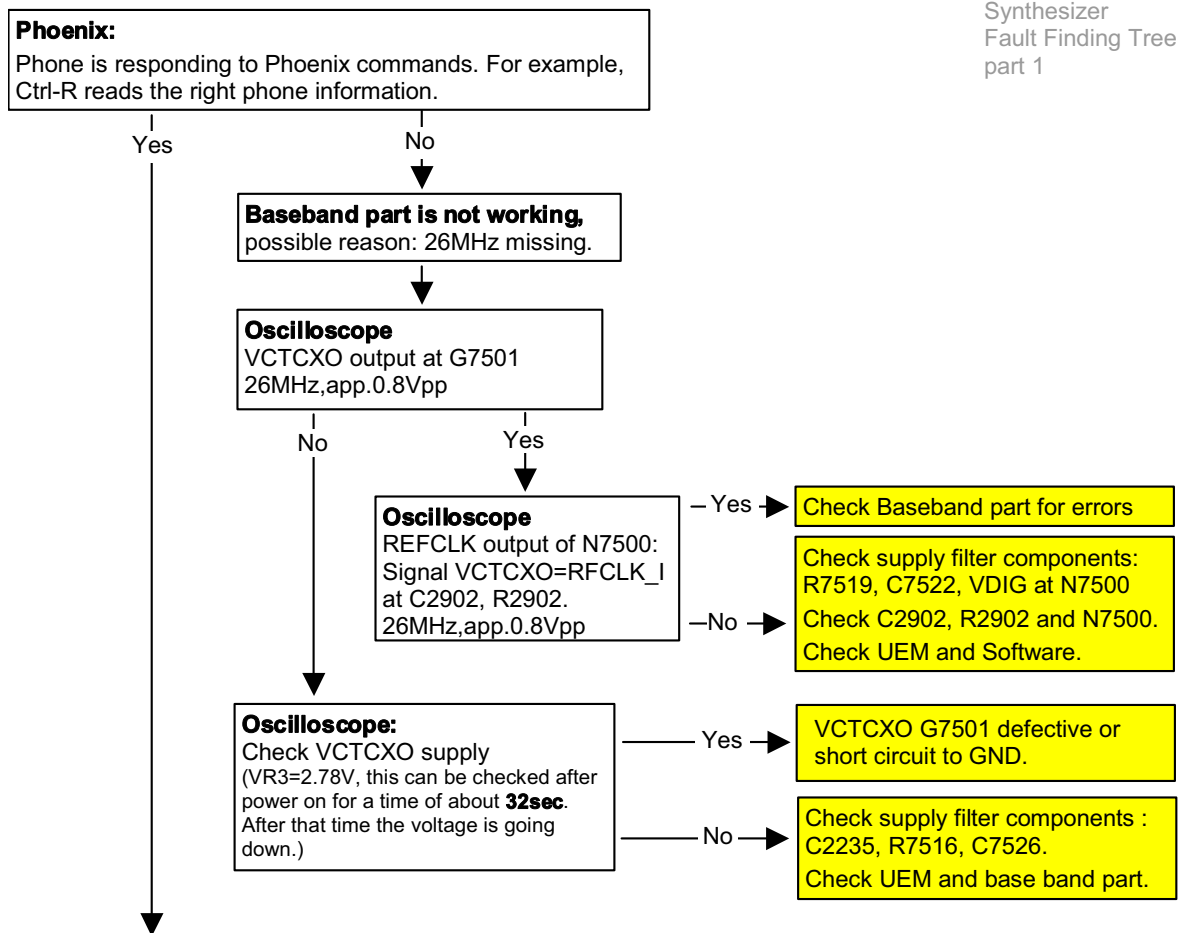

Synthesizer  
Fault Finding Tree  
part 2

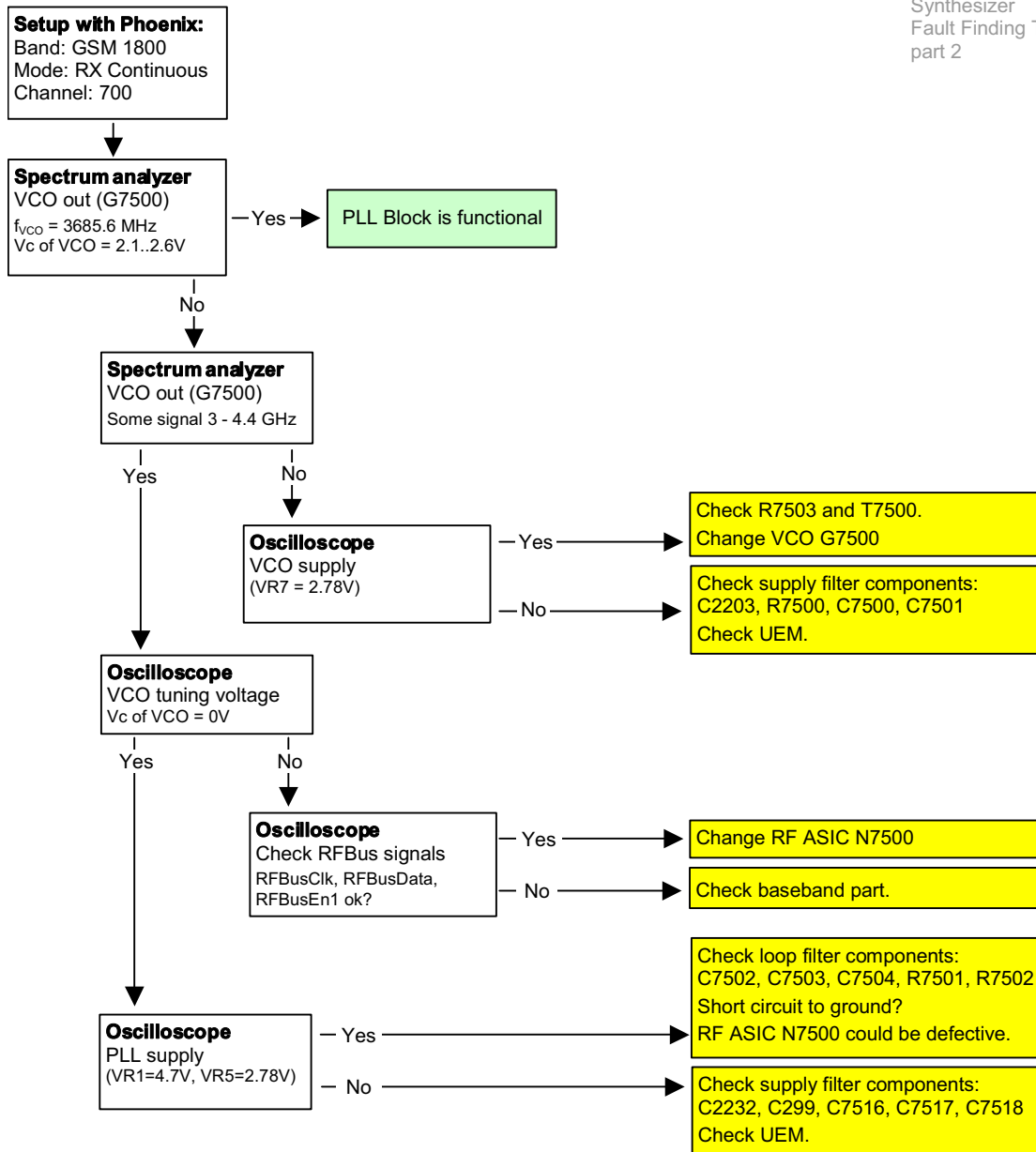

It is important to note that the power supply VR3 of the VCTCXO is only switched off in the so called 'Deep Sleep Mode' and the power supply VR7 of the VCO (G7500) is switched off in so called 'Sleep Mode'.

■ Frequency tables

GSM900 (including EGSM900)

Frequency list EGSM900														
CH	TX	RX	VCO TX	VCO RX	CH	TX	RX	VCO TX	VCO RX	CH	TX	RX	VCO TX	VCO RX
975	880.2	925.2	3520.8	3700.8	1	890.2	935.2	3560.8	3740.8	63	902.6	947.6	3610.4	3790.4
976	880.4	925.4	3521.6	3701.6	2	890.4	935.4	3561.6	3741.6	64	902.8	947.8	3611.2	3791.2
977	880.6	925.6	3522.4	3702.4	3	890.6	935.6	3562.4	3742.4	65	903.0	948.0	3612.0	3792.0
978	880.8	925.8	3523.2	3703.2	4	890.8	935.8	3563.2	3743.2	66	903.2	948.2	3612.8	3792.8
979	881.0	926.0	3524.0	3704.0	5	891.0	936.0	3564.0	3744.0	67	903.4	948.4	3613.6	3793.6
980	881.2	926.2	3524.8	3704.8	6	891.2	936.2	3564.8	3744.8	68	903.6	948.6	3614.4	3794.4
981	881.4	926.4	3525.6	3705.6	7	891.4	936.4	3565.6	3745.6	69	903.8	948.8	3615.2	3795.2
982	881.6	926.6	3526.4	3706.4	8	891.6	936.6	3566.4	3746.4	70	904.0	949.0	3616.0	3796.0
983	881.8	926.8	3527.2	3707.2	9	891.8	936.8	3567.2	3747.2	71	904.2	949.2	3616.8	3796.8
984	882.0	927.0	3528.0	3708.0	10	892.0	937.0	3568.0	3748.0	72	904.4	949.4	3617.6	3797.6
985	882.2	927.2	3528.8	3708.8	11	892.2	937.2	3568.8	3748.8	73	904.6	949.6	3618.4	3798.4
986	882.4	927.4	3529.6	3709.6	12	892.4	937.4	3569.6	3749.6	74	904.8	949.8	3619.2	3799.2
987	882.6	927.6	3530.4	3710.4	13	892.6	937.6	3570.4	3750.4	75	905.0	950.0	3620.0	3800.0
988	882.8	927.8	3531.2	3711.2	14	892.8	937.8	3571.2	3751.2	76	905.2	950.2	3620.8	3800.8
989	883.0	928.0	3532.0	3712.0	15	893.0	938.0	3572.0	3752.0	77	905.4	950.4	3621.6	3801.6
990	883.2	928.2	3532.8	3712.8	16	893.2	938.2	3572.8	3752.8	78	905.6	950.6	3622.4	3802.4
991	883.4	928.4	3533.6	3713.6	17	893.4	938.4	3573.6	3753.6	79	905.8	950.8	3623.2	3803.2
992	883.6	928.6	3534.4	3714.4	18	893.6	938.6	3574.4	3754.4	80	906.0	951.0	3624.0	3804.0
993	883.8	928.8	3535.2	3715.2	19	893.8	938.8	3575.2	3755.2	81	906.2	951.2	3624.8	3804.8
994	884.0	929.0	3536.0	3716.0	20	894.0	939.0	3576.0	3756.0	82	906.4	951.4	3625.6	3805.6
995	884.2	929.2	3536.8	3716.8	21	894.2	939.2	3576.8	3756.8	83	906.6	951.6	3626.4	3806.4
996	884.4	929.4	3537.6	3717.6	22	894.4	939.4	3577.6	3757.6	84	906.8	951.8	3627.2	3807.2
997	884.6	929.6	3538.4	3718.4	23	894.6	939.6	3578.4	3758.4	85	907.0	952.0	3628.0	3808.0
998	884.8	929.8	3539.2	3719.2	24	894.8	939.8	3579.2	3759.2	86	907.2	952.2	3628.8	3808.8
999	885.0	930.0	3540.0	3720.0	25	895.0	940.0	3580.0	3760.0	87	907.4	952.4	3629.6	3809.6
1000	885.2	930.2	3540.8	3720.8	26	895.2	940.2	3580.8	3760.8	88	907.6	952.6	3630.4	3810.4
1001	885.4	930.4	3541.6	3721.6	27	895.4	940.4	3581.6	3761.6	89	907.8	952.8	3631.2	3811.2
1002	885.6	930.6	3542.4	3722.4	28	895.6	940.6	3582.4	3762.4	90	908.0	953.0	3632.0	3812.0
1003	885.8	930.8	3543.2	3723.2	29	895.8	940.8	3583.2	3763.2	91	908.2	953.2	3632.8	3812.8
1004	886.0	931.0	3544.0	3724.0	30	896.0	941.0	3584.0	3764.0	92	908.4	953.4	3633.6	3813.6
1005	886.2	931.2	3544.8	3724.8	31	896.2	941.2	3584.8	3764.8	93	908.6	953.6	3634.4	3814.4
1006	886.4	931.4	3545.6	3725.6	32	896.4	941.4	3585.6	3765.6	94	908.8	953.8	3635.2	3815.2
1007	886.6	931.6	3546.4	3726.4	33	896.6	941.6	3586.4	3766.4	95	909.0	954.0	3636.0	3816.0
1008	886.8	931.8	3547.2	3727.2	34	896.8	941.8	3587.2	3767.2	96	909.2	954.2	3636.8	3816.8
1009	887.0	932.0	3548.0	3728.0	35	897.0	942.0	3588.0	3768.0	97	909.4	954.4	3637.6	3817.6
1010	887.2	932.2	3548.8	3728.8	36	897.2	942.2	3588.8	3768.8	98	909.6	954.6	3638.4	3818.4
1011	887.4	932.4	3549.6	3729.6	37	897.4	942.4	3589.6	3769.6	99	909.8	954.8	3639.2	3819.2
1012	887.6	932.6	3550.4	3730.4	38	897.6	942.6	3590.4	3770.4	100	910.0	955.0	3640.0	3820.0
1013	887.8	932.8	3551.2	3731.2	39	897.8	942.8	3591.2	3771.2	101	910.2	955.2	3640.8	3820.8
1014	888.0	933.0	3552.0	3732.0	40	898.0	943.0	3592.0	3772.0	102	910.4	955.4	3641.6	3821.6
1015	888.2	933.2	3552.8	3732.8	41	898.2	943.2	3592.8	3772.8	103	910.6	955.6	3642.4	3822.4
1016	888.4	933.4	3553.6	3733.6	42	898.4	943.4	3593.6	3773.6	104	910.8	955.8	3643.2	3823.2
1017	888.6	933.6	3554.4	3734.4	43	898.6	943.6	3594.4	3774.4	105	911.0	956.0	3644.0	3824.0
1018	888.8	933.8	3555.2	3735.2	44	898.8	943.8	3595.2	3775.2	106	911.2	956.2	3644.8	3824.8
1019	889.0	934.0	3556.0	3736.0	45	899.0	944.0	3596.0	3776.0	107	911.4	956.4	3645.6	3825.6
1020	889.2	934.2	3556.8	3736.8	46	899.2	944.2	3596.8	3776.8	108	911.6	956.6	3646.4	3826.4
1021	889.4	934.4	3557.6	3737.6	47	899.4	944.4	3597.6	3777.6	109	911.8	956.8	3647.2	3827.2
1022	889.6	934.6	3558.4	3738.4	48	899.6	944.6	3598.4	3778.4	110	912.0	957.0	3648.0	3828.0
1023	889.8	934.8	3559.2	3739.2	49	899.8	944.8	3599.2	3779.2	111	912.2	957.2	3648.8	3828.8
0	890.0	935.0	3560.0	3740.0	50	900.0	945.0	3600.0	3780.0	112	912.4	957.4	3649.6	3829.6
					51	900.2	945.2	3600.8	3780.8	113	912.6	957.6	3650.4	3830.4
					52	900.4	945.4	3601.6	3781.6	114	912.8	957.8	3651.2	3831.2
					53	900.6	945.6	3602.4	3782.4	115	913.0	958.0	3652.0	3832.0
					54	900.8	945.8	3603.2	3783.2	116	913.2	958.2	3652.8	3832.8
					55	901.0	946.0	3604.0	3784.0	117	913.4	958.4	3653.6	3833.6
					56	901.2	946.2	3604.8	3784.8	118	913.6	958.6	3654.4	3834.4
					57	901.4	946.4	3605.6	3785.6	119	913.8	958.8	3655.2	3835.2
					58	901.6	946.6	3606.4	3786.4	120	914.0	959.0	3656.0	3836.0
					59	901.8	946.8	3607.2	3787.2	121	914.2	959.2	3656.8	3836.8
					60	902.0	947.0	3608.0	3788.0	122	914.4	959.4	3657.6	3837.6
					61	902.2	947.2	3608.8	3788.8	123	914.6	959.6	3658.4	3838.4
					62	902.4	947.4	3609.6	3789.6	124	914.8	959.8	3659.2	3839.2

GSM1800

Frequency list GSM1800																			
GH	TX	RX	VCO TX	VCO RX	CH	TX	RX	VCO TX	VCO RX	CH	TX	RX	VCO TX	VCO RX	CH	TX	RX	VCO TX	VCO RX
512	1710.2	1805.2	3420.4	3610.4	606	1729.0	1824.0	3458.0	3648.0	700	1747.8	1842.8	3495.6	3685.6	794	1766.6	1861.6	3533.2	3723.2
513	1710.4	1805.4	3420.8	3610.8	607	1729.2	1824.2	3458.4	3648.4	701	1748.0	1843.0	3496.0	3686.0	795	1766.8	1861.8	3533.6	3723.6
514	1710.6	1805.6	3421.2	3611.2	608	1729.4	1824.4	3458.8	3648.8	702	1748.2	1843.2	3496.4	3686.4	796	1767.0	1862.0	3534.0	3724.0
515	1710.8	1805.8	3421.6	3611.6	609	1729.6	1824.6	3459.2	3649.2	703	1748.4	1843.4	3496.8	3686.8	797	1767.2	1862.2	3534.4	3724.4
516	1711.0	1806.0	3422.0	3612.0	610	1729.8	1824.8	3459.6	3649.6	704	1748.6	1843.6	3497.2	3687.2	798	1767.4	1862.4	3534.8	3724.8
517	1711.2	1806.2	3422.4	3612.4	611	1730.0	1825.0	3460.0	3650.0	705	1748.8	1843.8	3497.6	3687.6	799	1767.6	1862.6	3535.2	3725.2
518	1711.4	1806.4	3422.8	3612.8	612	1730.2	1825.2	3460.4	3650.4	706	1749.0	1844.0	3498.0	3688.0	800	1767.8	1862.8	3535.6	3725.6
519	1711.6	1806.6	3423.2	3613.2	613	1730.4	1825.4	3460.8	3650.8	707	1749.2	1844.2	3498.4	3688.4	801	1768.0	1863.0	3536.0	3726.0
520	1711.8	1806.8	3423.6	3613.6	614	1730.6	1825.6	3461.2	3651.2	708	1749.4	1844.4	3498.8	3688.8	802	1768.2	1863.2	3536.4	3726.4
521	1712.0	1807.0	3424.0	3614.0	615	1730.8	1825.8	3461.6	3651.6	709	1749.6	1844.6	3499.2	3689.2	803	1768.4	1863.4	3536.8	3726.8
522	1712.2	1807.2	3424.4	3614.4	616	1731.0	1826.0	3462.0	3652.0	710	1749.8	1844.8	3499.6	3689.6	804	1768.6	1863.6	3537.2	3727.2
523	1712.4	1807.4	3424.8	3614.8	617	1731.2	1826.2	3462.4	3652.4	711	1750.0	1845.0	3500.0	3690.0	805	1768.8	1863.8	3537.6	3727.6
524	1712.6	1807.6	3425.2	3615.2	618	1731.4	1826.4	3462.8	3652.8	712	1750.2	1845.2	3500.4	3690.4	806	1769.0	1864.0	3538.0	3728.0
525	1712.8	1807.8	3425.6	3615.6	619	1731.6	1826.6	3463.2	3653.2	713	1750.4	1845.4	3500.8	3690.8	807	1769.2	1864.2	3538.4	3728.4
526	1713.0	1808.0	3426.0	3616.0	620	1731.8	1826.8	3463.6	3653.6	714	1750.6	1845.6	3501.2	3691.2	808	1769.4	1864.4	3538.8	3728.8
527	1713.2	1808.2	3426.4	3616.4	621	1732.0	1827.0	3464.0	3654.0	715	1750.8	1845.8	3501.6	3691.6	809	1769.6	1864.6	3539.2	3729.2
528	1713.4	1808.4	3426.8	3616.8	622	1732.2	1827.2	3464.4	3654.4	716	1751.0	1846.0	3502.0	3692.0	810	1769.8	1864.8	3539.6	3729.6
529	1713.6	1808.6	3427.2	3617.2	623	1732.4	1827.4	3464.8	3654.8	717	1751.2	1846.2	3502.4	3692.4	811	1770.0	1865.0	3540.0	3730.0
530	1713.8	1808.8	3427.6	3617.6	624	1732.6	1827.6	3465.2	3655.2	718	1751.4	1846.4	3502.8	3692.8	812	1770.2	1865.2	3540.4	3730.4
531	1714.0	1809.0	3428.0	3618.0	625	1732.8	1827.8	3465.6	3655.6	719	1751.6	1846.6	3503.2	3693.2	813	1770.4	1865.4	3540.8	3730.8
532	1714.2	1809.2	3428.4	3618.4	626	1733.0	1828.0	3466.0	3656.0	720	1751.8	1846.8	3503.6	3693.6	814	1770.6	1865.6	3541.2	3731.2
533	1714.4	1809.4	3428.8	3618.8	627	1733.2	1828.2	3466.4	3656.4	721	1752.0	1847.0	3504.0	3694.0	815	1770.8	1865.8	3541.6	3731.6
534	1714.6	1809.6	3429.2	3619.2	628	1733.4	1828.4	3466.8	3656.8	722	1752.2	1847.2	3504.4	3694.4	816	1771.0	1866.0	3542.0	3732.0
535	1714.8	1809.8	3429.6	3619.6	629	1733.6	1828.6	3467.2	3657.2	723	1752.4	1847.4	3504.8	3694.8	817	1771.2	1866.2	3542.4	3732.4
536	1715.0	1810.0	3430.0	3620.0	630	1733.8	1828.8	3467.6	3657.6	724	1752.6	1847.6	3505.2	3695.2	818	1771.4	1866.4	3542.8	3732.8
537	1715.2	1810.2	3430.4	3620.4	631	1734.0	1829.0	3468.0	3658.0	725	1752.8	1847.8	3505.6	3695.6	819	1771.6	1866.6	3543.2	3733.2
538	1715.4	1810.4	3430.8	3620.8	632	1734.2	1829.2	3468.4	3658.4	726	1753.0	1848.0	3506.0	3696.0	820	1771.8	1866.8	3543.6	3733.6
539	1715.6	1810.6	3431.2	3621.2	633	1734.4	1829.4	3468.8	3658.8	727	1753.2	1848.2	3506.4	3696.4	821	1772.0	1867.0	3544.0	3734.0
540	1715.8	1810.8	3431.6	3621.6	634	1734.6	1829.6	3469.2	3659.2	728	1753.4	1848.4	3506.8	3696.8	822	1772.2	1867.2	3544.4	3734.4
541	1716.0	1811.0	3432.0	3622.0	635	1734.8	1829.8	3469.6	3659.6	729	1753.6	1848.6	3507.2	3697.2	823	1772.4	1867.4	3544.8	3734.8
542	1716.2	1811.2	3432.4	3622.4	636	1735.0	1830.0	3470.0	3660.0	730	1753.8	1848.8	3507.6	3697.6	824	1772.6	1867.6	3545.2	3735.2
543	1716.4	1811.4	3432.8	3622.8	637	1735.2	1830.2	3470.4	3660.4	731	1754.0	1849.0	3508.0	3698.0	825	1772.8	1867.8	3545.6	3735.6
544	1716.6	1811.6	3433.2	3623.2	638	1735.4	1830.4	3470.8	3660.8	732	1754.2	1849.2	3508.4	3698.4	826	1773.0	1868.0	3546.0	3736.0
545	1716.8	1811.8	3433.6	3623.6	639	1735.6	1830.6	3471.2	3661.2	733	1754.4	1849.4	3508.8	3698.8	827	1773.2	1868.2	3546.4	3736.4
546	1717.0	1812.0	3434.0	3624.0	640	1735.8	1830.8	3471.6	3661.6	734	1754.6	1849.6	3509.2	3699.2	828	1773.4	1868.4	3546.8	3736.8
547	1717.2	1812.2	3434.4	3624.4	641	1736.0	1831.0	3472.0	3662.0	735	1754.8	1849.8	3509.6	3699.6	829	1773.6	1868.6	3547.2	3737.2
548	1717.4	1812.4	3434.8	3624.8	642	1736.2	1831.2	3472.4	3662.4	736	1755.0	1850.0	3510.0	3700.0	830	1773.8	1868.8	3547.6	3737.6
549	1717.6	1812.6	3435.2	3625.2	643	1736.4	1831.4	3472.8	3662.8	737	1755.2	1850.2	3510.4	3700.4	831	1774.0	1869.0	3548.0	3738.0
550	1717.8	1812.8	3435.6	3625.6	644	1736.6	1831.6	3473.2	3663.2	738	1755.4	1850.4	3510.8	3700.8	832	1774.2	1869.2	3548.4	3738.4
551	1718.0	1813.0	3436.0	3626.0	645	1736.8	1831.8	3473.6	3663.6	739	1755.6	1850.6	3511.2	3701.2	833	1774.4	1869.4	3548.8	3738.8
552	1718.2	1813.2	3436.4	3626.4	646	1737.0	1832.0	3474.0	3664.0	740	1755.8	1850.8	3511.6	3701.6	834	1774.6	1869.6	3549.2	3739.2
553	1718.4	1813.4	3436.8	3626.8	647	1737.2	1832.2	3474.4	3664.4	741	1756.0	1851.0	3512.0	3702.0	835	1774.8	1869.8	3549.6	3739.6
554	1718.6	1813.6	3437.2	3627.2	648	1737.4	1832.4	3474.8	3664.8	742	1756.2	1851.2	3512.4	3702.4	836	1775.0	1870.0	3550.0	3740.0
555	1718.8	1813.8	3437.6	3627.6	649	1737.6	1832.6	3475.2	3665.2	743	1756.4	1851.4	3512.8	3702.8	837	1775.2	1870.2	3550.4	3740.4
556	1719.0	1814.0	3438.0	3628.0	650	1737.8	1832.8	3475.6	3665.6	744	1756.6	1851.6	3513.2	3703.2	838	1775.4	1870.4	3550.8	3740.8
557	1719.2	1814.2	3438.4	3628.4	651	1738.0	1833.0	3476.0	3666.0	745	1756.8	1851.8	3513.6	3703.6	839	1775.6	1870.6	3551.2	3741.2
558	1719.4	1814.4	3438.8	3628.8	652	1738.2	1833.2	3476.4	3666.4	746	1757.0	1852.0	3514.0	3704.0	840	1775.8	1870.8	3551.6	3741.6
559	1719.6	1814.6	3439.2	3629.2	653	1738.4	1833.4	3476.8	3666.8	747	1757.2	1852.2	3514.4	3704.4	841	1776.0	1871.0	3552.0	3742.0
560	1719.8	1814.8	3439.6	3629.6	654	1738.6	1833.6	3477.2	3667.2	748	1757.4	1852.4	3514.8	3704.8	842	1776.2	1871.2	3552.4	3742.4
561	1720.0	1815.0	3440.0	3630.0	655	1738.8	1833.8	3477.6	3667.6	749	1757.6	1852.6	3515.2	3705.2	843	1776.4	1871.4	3552.8	3742.8
562	1720.2	1815.2	3440.4	3630.4	656	1739.0	1834.0	3478.0	3668.0	750	1757.8	1852.8	3515.6	3705.6	844	1776.6	1871.6	3553.2	3743.2
563	1720.4	1815.4	3440.8	3630.8	657	1739.2	1834.2	3478.4	3668.4	751	1758.0	1853.0	3516.0	3706.0	845	1776.8	1871.8	3553.6	3743.6
564	1720.6	1815.6	3441.2	3631.2	658	1739.4	1834.4	3478.8	3668.8	752	1758.2	1853.2	3516.4	3706.4	846	1777.0	1872.0	3554.0	3744.0
565	1720.8	1815.8	3441.6	3631.6	659	1739.6	1834.6	3479.2	3669.2	753	1758.4	1853.4	3516.8	3706.8	847	1777.2	1872.2	3554.4	3744.4
566	1721.0	1816.0	3442.0	3632.0	660	1739.8	1834.8	3479.6	3669.6	754	1758.6	1853.6	3517.2	3707.2	848	1777.4	1872.4	3554.8	3744.8
567	1721.2	1816.2	3442.4	3632.4	661	1740.0	1835.0	3480.0	3670.0	755	1758.8	1853.8	3517.6	3707.6	849	1777.6	1872.6	3555.2	3745.2
568	1721.4	1816.4	3442.8</																

570	1721.8	1816.8	3443.6	3633.6	664	1740.6	1835.6	3481.2	3671.2	758	1759.4	1854.4	3518.8	3708.8	852	1778.2	1873.2	3556.4	3746.4
571	1722.0	1817.0	3444.0	3634.0	665	1740.8	1835.8	3481.6	3671.6	759	1759.6	1854.6	3519.2	3709.2	853	1778.4	1873.4	3556.8	3746.8
572	1722.2	1817.2	3444.4	3634.4	666	1741.0	1836.0	3482.0	3672.0	760	1759.8	1854.8	3519.6	3709.6	854	1778.6	1873.6	3557.2	3747.2
573	1722.4	1817.4	3444.8	3634.8	667	1741.2	1836.2	3482.4	3672.4	761	1760.0	1855.0	3520.0	3710.0	855	1778.8	1873.8	3557.6	3747.6
574	1722.6	1817.6	3445.2	3635.2	668	1741.4	1836.4	3482.8	3672.8	762	1760.2	1855.2	3520.4	3710.4	856	1779.0	1874.0	3558.0	3748.0
575	1722.8	1817.8	3445.6	3635.6	669	1741.6	1836.6	3483.2	3673.2	763	1760.4	1855.4	3520.8	3710.8	857	1779.2	1874.2	3558.4	3748.4
576	1723.0	1818.0	3446.0	3636.0	670	1741.8	1836.8	3483.6	3673.6	764	1760.6	1855.6	3521.2	3711.2	858	1779.4	1874.4	3558.8	3748.8
577	1723.2	1818.2	3446.4	3636.4	671	1742.0	1837.0	3484.0	3674.0	765	1760.8	1855.8	3521.6	3711.6	859	1779.6	1874.6	3559.2	3749.2
578	1723.4	1818.4	3446.8	3636.8	672	1742.2	1837.2	3484.4	3674.4	766	1761.0	1856.0	3522.0	3712.0	860	1779.8	1874.8	3559.6	3749.6
579	1723.6	1818.6	3447.2	3637.2	673	1742.4	1837.4	3484.8	3674.8	767	1761.2	1856.2	3522.4	3712.4	861	1780.0	1875.0	3560.0	3750.0
580	1723.8	1818.8	3447.6	3637.6	674	1742.6	1837.6	3485.2	3675.2	768	1761.4	1856.4	3522.8	3712.8	862	1780.2	1875.2	3560.4	3750.4
581	1724.0	1819.0	3448.0	3638.0	675	1742.8	1837.8	3485.6	3675.6	769	1761.6	1856.6	3523.2	3713.2	863	1780.4	1875.4	3560.8	3750.8
582	1724.2	1819.2	3448.4	3638.4	676	1743.0	1838.0	3486.0	3676.0	770	1761.8	1856.8	3523.6	3713.6	864	1780.6	1875.6	3561.2	3751.2
583	1724.4	1819.4	3448.8	3638.8	677	1743.2	1838.2	3486.4	3676.4	771	1762.0	1857.0	3524.0	3714.0	865	1780.8	1875.8	3561.6	3751.6
584	1724.6	1819.6	3449.2	3639.2	678	1743.4	1838.4	3486.8	3676.8	772	1762.2	1857.2	3524.4	3714.4	866	1781.0	1876.0	3562.0	3752.0
585	1724.8	1819.8	3449.6	3639.6	679	1743.6	1838.6	3487.2	3677.2	773	1762.4	1857.4	3524.8	3714.8	867	1781.2	1876.2	3562.4	3752.4
586	1725.0	1820.0	3450.0	3640.0	680	1743.8	1838.8	3487.6	3677.6	774	1762.6	1857.6	3525.2	3715.2	868	1781.4	1876.4	3562.8	3752.8
587	1725.2	1820.2	3450.4	3640.4	681	1744.0	1839.0	3488.0	3678.0	775	1762.8	1857.8	3525.6	3715.6	869	1781.6	1876.6	3563.2	3753.2
588	1725.4	1820.4	3450.8	3640.8	682	1744.2	1839.2	3488.4	3678.4	776	1763.0	1858.0	3526.0	3716.0	870	1781.8	1876.8	3563.6	3753.6
589	1725.6	1820.6	3451.2	3641.2	683	1744.4	1839.4	3488.8	3678.8	777	1763.2	1858.2	3526.4	3716.4	871	1782.0	1877.0	3564.0	3754.0
590	1725.8	1820.8	3451.6	3641.6	684	1744.6	1839.6	3489.2	3679.2	778	1763.4	1858.4	3526.8	3716.8	872	1782.2	1877.2	3564.4	3754.4
591	1726.0	1821.0	3452.0	3642.0	685	1744.8	1839.8	3489.6	3679.6	779	1763.6	1858.6	3527.2	3717.2	873	1782.4	1877.4	3564.8	3754.8
592	1726.2	1821.2	3452.4	3642.4	686	1745.0	1840.0	3490.0	3680.0	780	1763.8	1858.8	3527.6	3717.6	874	1782.6	1877.6	3565.2	3755.2
593	1726.4	1821.4	3452.8	3642.8	687	1745.2	1840.2	3490.4	3680.4	781	1764.0	1859.0	3528.0	3718.0	875	1782.8	1877.8	3565.6	3755.6
594	1726.6	1821.6	3453.2	3643.2	688	1745.4	1840.4	3490.8	3680.8	782	1764.2	1859.2	3528.4	3718.4	876	1783.0	1878.0	3566.0	3756.0
595	1726.8	1821.8	3453.6	3643.6	689	1745.6	1840.6	3491.2	3681.2	783	1764.4	1859.4	3528.8	3718.8	877	1783.2	1878.2	3566.4	3756.4
596	1727.0	1822.0	3454.0	3644.0	690	1745.8	1840.8	3491.6	3681.6	784	1764.6	1859.6	3529.2	3719.2	878	1783.4	1878.4	3566.8	3756.8
597	1727.2	1822.2	3454.4	3644.4	691	1746.0	1841.0	3492.0	3682.0	785	1764.8	1859.8	3529.6	3719.6	879	1783.6	1878.6	3567.2	3757.2
598	1727.4	1822.4	3454.8	3644.8	692	1746.2	1841.2	3492.4	3682.4	786	1765.0	1860.0	3530.0	3720.0	880	1783.8	1878.8	3567.6	3757.6
599	1727.6	1822.6	3455.2	3645.2	693	1746.4	1841.4	3492.8	3682.8	787	1765.2	1860.2	3530.4	3720.4	881	1784.0	1879.0	3568.0	3758.0
600	1727.8	1822.8	3455.6	3645.6	694	1746.6	1841.6	3493.2	3683.2	788	1765.4	1860.4	3530.8	3720.8	882	1784.2	1879.2	3568.4	3758.4
601	1728.0	1823.0	3456.0	3646.0	695	1746.8	1841.8	3493.6	3683.6	789	1765.6	1860.6	3531.2	3721.2	883	1784.4	1879.4	3568.8	3758.8
602	1728.2	1823.2	3456.4	3646.4	696	1747.0	1842.0	3494.0	3684.0	790	1765.8	1860.8	3531.6	3721.6	884	1784.6	1879.6	3569.2	3759.2
603	1728.4	1823.4	3456.8	3646.8	697	1747.2	1842.2	3494.4	3684.4	791	1766.0	1861.0	3532.0	3722.0	885	1784.8	1879.8	3569.6	3759.6
604	1728.6	1823.6	3457.2	3647.2	698	1747.4	1842.4	3494.8	3684.8	792	1766.2	1861.2	3532.4	3722.4					
605	1728.8	1823.8	3457.6	3647.6	699	1747.6	1842.6	3495.2	3685.2	793	1766.4	1861.4	3532.8	3722.8					

GSM1900

Frequency list NPL-2 GSM1900																			
CH	TX	RX	VCO TX	VCO RX	CH	TX	RX	VCO TX	VCO RX	CH	TX	RX	VCO TX	VCO RX	CH	TX	RX	VCO TX	VCO RX
512	1850.2	1930.2	3700.4	3860.4	606	1869.0	1949.0	3738.0	3898.0	700	1887.8	1967.8	3775.6	3935.6	794	1906.6	1986.6	3813.2	3973.2
513	1850.4	1930.4	3700.8	3860.8	607	1869.2	1949.2	3738.4	3898.4	701	1888.0	1968.0	3776.0	3936.0	795	1906.8	1986.8	3813.6	3973.6
514	1850.6	1930.6	3701.2	3861.2	608	1869.4	1949.4	3738.8	3898.8	702	1888.2	1968.2	3776.4	3936.4	796	1907.0	1987.0	3814.0	3974.0
515	1850.8	1930.8	3701.6	3861.6	609	1869.6	1949.6	3739.2	3899.2	703	1888.4	1968.4	3776.8	3936.8	797	1907.2	1987.2	3814.4	3974.4
516	1851.0	1931.0	3702.0	3862.0	610	1869.8	1949.8	3739.6	3899.6	704	1888.6	1968.6	3777.2	3937.2	798	1907.4	1987.4	3814.8	3974.8
517	1851.2	1931.2	3702.4	3862.4	611	1870.0	1950.0	3740.0	3900.0	705	1888.8	1968.8	3777.6	3937.6	799	1907.6	1987.6	3815.2	3975.2
518	1851.4	1931.4	3702.8	3862.8	612	1870.2	1950.2	3740.4	3900.4	706	1889.0	1969.0	3778.0	3938.0	800	1907.8	1987.8	3815.6	3975.6
519	1851.6	1931.6	3703.2	3863.2	613	1870.4	1950.4	3740.8	3900.8	707	1889.2	1969.2	3778.4	3938.4	801	1908.0	1988.0	3816.0	3976.0
520	1851.8	1931.8	3703.6	3863.6	614	1870.6	1950.6	3741.2	3901.2	708	1889.4	1969.4	3778.8	3938.8	802	1908.2	1988.2	3816.4	3976.4
521	1852.0	1932.0	3704.0	3864.0	615	1870.8	1950.8	3741.6	3901.6	709	1889.6	1969.6	3779.2	3939.2	803	1908.4	1988.4	3816.8	3976.8
522	1852.2	1932.2	3704.4	3864.4	616	1871.0	1951.0	3742.0	3902.0	710	1889.8	1969.8	3779.6	3939.6	804	1908.6	1988.6	3817.2	3977.2
523	1852.4	1932.4	3704.8	3864.8	617	1871.2	1951.2	3742.4	3902.4	711	1890.0	1970.0	3780.0	3940.0	805	1908.8	1988.8	3817.6	3977.6
524	1852.6	1932.6	3705.2	3865.2	618	1871.4	1951.4	3742.8	3902.8	712	1890.2	1970.2	3780.4	3940.4	806	1909.0	1989.0	3818.0	3978.0
525	1852.8	1932.8	3705.6	3865.6	619	1871.6	1951.6	3743.2	3903.2	713	1890.4	1970.4	3780.8	3940.8	807	1909.2	1989.2	3818.4	3978.4
526	1853.0	1933.0	3706.0	3866.0	620	1871.8	1951.8	3743.6	3903.6	714	1890.6	1970.6	3781.2	3941.2	808	1909.4	1989.4	3818.8	3978.8
527	1853.2	1933.2	3706.4	3866.4	621	1872.0	1952.0	3744.0	3904.0	715	1890.8	1970.8	3781.6	3941.6	809	1909.6	1989.6	3819.2	3979.2
528	1853.4	1933.4	3706.8	3866.8	622	1872.2	1952.2	3744.4	3904.4	716	1891.0	1971.0	3782.0	3942.0	810	1909.8	1989.8	3819.6	3979.6
529	1853.6	1933.6	3707.2	3867.2	623	1872.4	1952.4	3744.8	3904.8	717	1891.2	1971.2	3782.4	3942.4					
530	1853.8	1933.8	3707.6	3867.6	624	1872.6	1952.6	3745.2	3905.2	718	1891.4	1971.4	3782.8	3942.8					
531	1854.0	1934.0	3708.0	3868.0	625	1872.8	1952.8	3745.6	3905.6	719	1891.6	1971.6	3783.2	3943.2					
532	1854.2	1934.2	3708.4	3868.4	626	1873.0	1953.0	3746.0	3906.0	720	1891.8	1971.8	3783.6	3943.6					
533	1854.4	1934.4	3708.8	3868.8	627	1873.2	1953.2	3746.4	3906.4	721	1892.0	1972.0	3784.0	3944.0					
534	1854.6	1934.6	3709.2	3869.2	628	1873.4	1953.4	3746.8	3906.8	722	1892.2	1972.2	3784.4	3944.4					
535	1854.8	1934.8	3709.6	3869.6	629	1873.6	1953.6	3747.2	3907.2	723	1892.4	1972.4	3784.8	3944.8					
536	1855.0	1935.0	3710.0	3870.0	630	1873.8	1953.8	3747.6	3907.6	724	1892.6	1972.6	3785.2	3945.2					
537	1855.2	1935.2	3710.4	3870.4	631	1874.0	1954.0	3748.0	3908.0	725	1892.8	1972.8	3785.6	3945.6					
538	1855.4	1935.4	3710.8	3870.8	632	1874.2	1954.2	3748.4	3908.4	726	1893.0	1973.0	3786.0	3946.0					
539	1855.6	1935.6	3711.2	3871.2	633	1874.4	1954.4	3748.8	3908.8	727	1893.2	1973.2	3786.4	3946.4					
540	1855.8	1935.8	3711.6	3871.6	634	1874.6	1954.6	3749.2	3909.2	728	1893.4	1973.4	3786.8	3946.8					
541	1856.0	1936.0	3712.0	3872.0	635	1874.8	1954.8	3749.6	3909.6	729	1893.6	1973.6	3787.2	3947.2					
542	1856.2	1936.2	3712.4	3872.4	636	1875.0	1955.0	3750.0	3910.0	730	1893.8	1973.8	3787.6	3947.6					
543	1856.4	1936.4	3712.8	3872.8	637	1875.2	1955.2	3750.4	3910.4	731	1894.0	1974.0	3788.0	3948.0					
544	1856.6	1936.6	3713.2	3873.2	638	1875.4	1955.4	3750.8	3910.8	732	1894.2	1974.2	3788.4	3948.4					
545	1856.8	1936.8	3713.6	3873.6	639	1875.6	1955.6	3751.2	3911.2	733	1894.4	1974.4	3788.8	3948.8					
546	1857.0	1937.0	3714.0	3874.0	640	1875.8	1955.8	3751.6	3911.6	734	1894.6	1974.6	3789.2	3949.2					
547	1857.2	1937.2	3714.4	3874.4	641	1876.0	1956.0	3752.0	3912.0	735	1894.8	1974.8	3789.6	3949.6					
548	1857.4	1937.4	3714.8	3874.8	642	1876.2	1956.2	3752.4	3912.4	736	1895.0	1975.0	3790.0	3950.0					
549	1857.6	1937.6	3715.2	3875.2	643	1876.4	1956.4	3752.8	3912.8	737	1895.2	1975.2	3790.4	3950.4					
550	1857.8	1937.8	3715.6	3875.6	644	1876.6	1956.6	3753.2	3913.2	738	1895.4	1975.4	3790.8	3950.8					
551	1858.0	1938.0	3716.0	3876.0	645	1876.8	1956.8	3753.6	3913.6	739	1895.6	1975.6	3791.2	3951.2					
552	1858.2	1938.2	3716.4	3876.4	646	1877.0	1957.0	3754.0	3914.0	740	1895.8	1975.8	3791.6	3951.6					
553	1858.4	1938.4	3716.8	3876.8	647	1877.2	1957.2	3754.4	3914.4	741	1896.0	1976.0	3792.0	3952.0					
554	1858.6	1938.6	3717.2	3877.2	648	1877.4	1957.4	3754.8	3914.8	742	1896.2	1976.2	3792.4	3952.4					
555	1858.8	1938.8	3717.6	3877.6	649	1877.6	1957.6	3755.2	3915.2	743	1896.4	1976.4	3792.8	3952.8					
556	1859.0	1939.0	3718.0	3878.0	650	1877.8	1957.8	3755.6	3915.6	744	1896.6	1976.6	3793.2	3953.2					
557	1859.2	1939.2	3718.4	3878.4	651	1878.0	1958.0	3756.0	3916.0	745	1896.8	1976.8	3793.6	3953.6					
558	1859.4	1939.4	3718.8	3878.8	652	1878.2	1958.2	3756.4	3916.4	746	1897.0	1977.0	3794.0	3954.0					
559	1859.6	1939.6	3719.2	3879.2	653	1878.4	1958.4	3756.8	3916.8	747	1897.2	1977.2	3794.4	3954.4					
560	1859.8	1939.8	3719.6	3879.6	654	1878.6	1958.6	3757.2	3917.2	748	1897.4	1977.4	3794.8	3954.8					
561	1860.0	1940.0	3720.0	3880.0	655	1878.8	1958.8	3757.6	3917.6	749	1897.6	1977.6	3795.2	3955.2					
562	1860.2	1940.2	3720.4	3880.4	656	1879.0	1959.0	3758.0	3918.0	750	1897.8	1977.8	3795.6	3955.6					
563	1860.4	1940.4	3720.8	3880.8	657	1879.2	1959.2	3758.4	3918.4	751	1898.0	1978.0	3796.0	3956.0					
564	1860.6	1940.6	3721.2	3881.2	658	1879.4	1959.4	3758.8	3918.8	752	1898.2	1978.2	3796.4	3956.4					
565	1860.8	1940.8	3721.6	3881.6	659	1879.6	1959.6	3759.2	3919.2	753	1898.4	1978.4	3796.8	3956.8					
566	1861.0	1941.0	3722.0	3882.0	660	1879.8	1959.8	3759.6	3919.6	754	1898.6	1978.6	3797.2	3957.2					
567	1861.2	1941.2	3722.4	3882.4	661	1880.0	1960.0	3760.0	3920.0	755	1898.8	1978.8	3797.6	3957.6					
568	1861.4	1941.4	3722.8	3882.8	662	1880.2	1960.2	3760.4	3920.4	756	1899.0	1979.0	3798.0	3958.0					
569	1861.6	1941.6	3723.2	3883.2	663	1880.4	1960.4	3760.8	3920.8	757	1899.2	1979.2	3798.4	3958.4					
570	1861.8	1941.8	3723.6	3883.6	664	1880.6	1960.6	3761.2	3921.2	758	1899.4	1979.4	3798.8	3958.8					

571	1862.0	1942.0	3724.0	3884.0	665	1880.8	1960.8	3761.6	3921.6	759	1899.6	1979.6	3799.2	3959.2				
572	1862.2	1942.2	3724.4	3884.4	666	1881.0	1961.0	3762.0	3922.0	760	1899.8	1979.8	3799.6	3959.6				
573	1862.4	1942.4	3724.8	3884.8	667	1881.2	1961.2	3762.4	3922.4	761	1900.0	1980.0	3800.0	3960.0				
574	1862.6	1942.6	3725.2	3885.2	668	1881.4	1961.4	3762.8	3922.8	762	1900.2	1980.2	3800.4	3960.4				
575	1862.8	1942.8	3725.6	3885.6	669	1881.6	1961.6	3763.2	3923.2	763	1900.4	1980.4	3800.8	3960.8				
576	1863.0	1943.0	3726.0	3886.0	670	1881.8	1961.8	3763.6	3923.6	764	1900.6	1980.6	3801.2	3961.2				
577	1863.2	1943.2	3726.4	3886.4	671	1882.0	1962.0	3764.0	3924.0	765	1900.8	1980.8	3801.6	3961.6				
578	1863.4	1943.4	3726.8	3886.8	672	1882.2	1962.2	3764.4	3924.4	766	1901.0	1981.0	3802.0	3962.0				
579	1863.6	1943.6	3727.2	3887.2	673	1882.4	1962.4	3764.8	3924.8	767	1901.2	1981.2	3802.4	3962.4				
580	1863.8	1943.8	3727.6	3887.6	674	1882.6	1962.6	3765.2	3925.2	768	1901.4	1981.4	3802.8	3962.8				
581	1864.0	1944.0	3728.0	3888.0	675	1882.8	1962.8	3765.6	3925.6	769	1901.6	1981.6	3803.2	3963.2				
582	1864.2	1944.2	3728.4	3888.4	676	1883.0	1963.0	3766.0	3926.0	770	1901.8	1981.8	3803.6	3963.6				
583	1864.4	1944.4	3728.8	3888.8	677	1883.2	1963.2	3766.4	3926.4	771	1902.0	1982.0	3804.0	3964.0				
584	1864.6	1944.6	3729.2	3889.2	678	1883.4	1963.4	3766.8	3926.8	772	1902.2	1982.2	3804.4	3964.4				
585	1864.8	1944.8	3729.6	3889.6	679	1883.6	1963.6	3767.2	3927.2	773	1902.4	1982.4	3804.8	3964.8				
586	1865.0	1945.0	3730.0	3890.0	680	1883.8	1963.8	3767.6	3927.6	774	1902.6	1982.6	3805.2	3965.2				
587	1865.2	1945.2	3730.4	3890.4	681	1884.0	1964.0	3768.0	3928.0	775	1902.8	1982.8	3805.6	3965.6				
588	1865.4	1945.4	3730.8	3890.8	682	1884.2	1964.2	3768.4	3928.4	776	1903.0	1983.0	3806.0	3966.0				
589	1865.6	1945.6	3731.2	3891.2	683	1884.4	1964.4	3768.8	3928.8	777	1903.2	1983.2	3806.4	3966.4				
590	1865.8	1945.8	3731.6	3891.6	684	1884.6	1964.6	3769.2	3929.2	778	1903.4	1983.4	3806.8	3966.8				
591	1866.0	1946.0	3732.0	3892.0	685	1884.8	1964.8	3769.6	3929.6	779	1903.6	1983.6	3807.2	3967.2				
592	1866.2	1946.2	3732.4	3892.4	686	1885.0	1965.0	3770.0	3930.0	780	1903.8	1983.8	3807.6	3967.6				
593	1866.4	1946.4	3732.8	3892.8	687	1885.2	1965.2	3770.4	3930.4	781	1904.0	1984.0	3808.0	3968.0				
594	1866.6	1946.6	3733.2	3893.2	688	1885.4	1965.4	3770.8	3930.8	782	1904.2	1984.2	3808.4	3968.4				
595	1866.8	1946.8	3733.6	3893.6	689	1885.6	1965.6	3771.2	3931.2	783	1904.4	1984.4	3808.8	3968.8				
596	1867.0	1947.0	3734.0	3894.0	690	1885.8	1965.8	3771.6	3931.6	784	1904.6	1984.6	3809.2	3969.2				
597	1867.2	1947.2	3734.4	3894.4	691	1886.0	1966.0	3772.0	3932.0	785	1904.8	1984.8	3809.6	3969.6				
598	1867.4	1947.4	3734.8	3894.8	692	1886.2	1966.2	3772.4	3932.4	786	1905.0	1985.0	3810.0	3970.0				
599	1867.6	1947.6	3735.2	3895.2	693	1886.4	1966.4	3772.8	3932.8	787	1905.2	1985.2	3810.4	3970.4				
600	1867.8	1947.8	3735.6	3895.6	694	1886.6	1966.6	3773.2	3933.2	788	1905.4	1985.4	3810.8	3970.8				
601	1868.0	1948.0	3736.0	3896.0	695	1886.8	1966.8	3773.6	3933.6	789	1905.6	1985.6	3811.2	3971.2				
602	1868.2	1948.2	3736.4	3896.4	696	1887.0	1967.0	3774.0	3934.0	790	1905.8	1985.8	3811.6	3971.6				
603	1868.4	1948.4	3736.8	3896.8	697	1887.2	1967.2	3774.4	3934.4	791	1906.0	1986.0	3812.0	3972.0				
604	1868.6	1948.6	3737.2	3897.2	698	1887.4	1967.4	3774.8	3934.8	792	1906.2	1986.2	3812.4	3972.4				
605	1868.8	1948.8	3737.6	3897.6	699	1887.6	1967.6	3775.2	3935.2	793	1906.4	1986.4	3812.8	3972.8				



## DC Supply Voltage Check

For a quick check of DC power supplies, refer to the diagram below. The RF power supplies are generated in the UEM and can be measured either in the Small Signal Chamber or in the Base Band Chamber.

The UEM output voltages can be measured at the respective resistors' / capacitors' pads marked below in brackets, e.g. < C1234 >.

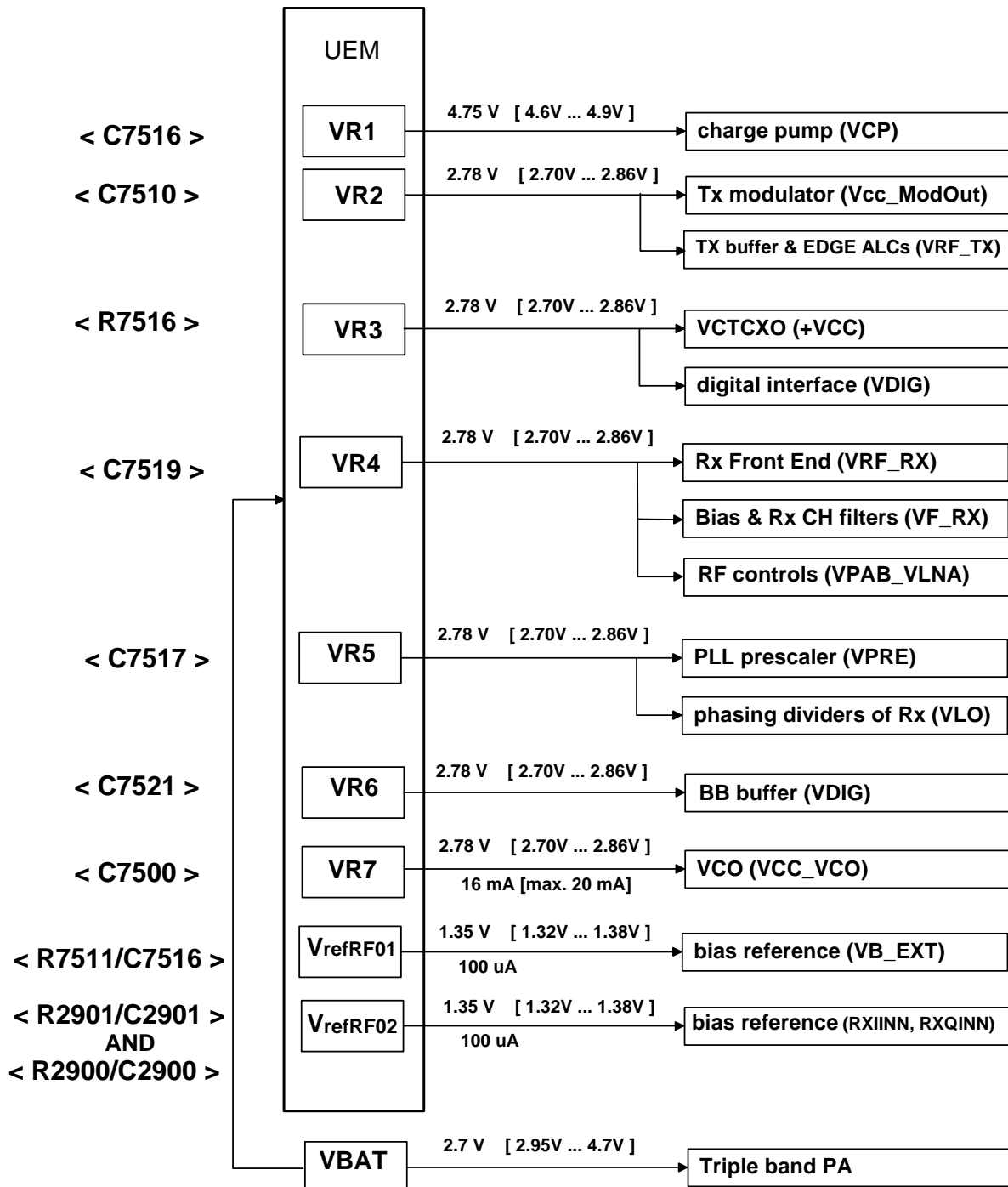

This page has been intentionally left blank.

# Nokia Customer Care

## Appendix 6A: Test Points

Receiver test points

<b>Testpoint</b>	<b>VR6</b>
Band	GSM900
Active Unit	RX
Operation Mode	Continuous or Burst
RX/TX Channel	37
DC Level	2.8 V

<b>Testpoint</b>	<b>VR4</b>
Band	GSM900
Active Unit	RX
Operation Mode	Continuous or Burst
RX/TX Channel	37
DC Level	2.8 V

<b>Testpoint</b>	<b>Rx 3</b>
Band	GSM1900
Active Unit	RX
Operation Mode	Continuous
RX/TX Channel	661
AGC	14
Input Power	-60dBm
Input Frequency	1960.06771MHz
Probed Power	Pref - 2.5dB

<b>Testpoint</b>	<b>Rx 2</b>
Band	GSM1800
Active Unit	RX
Operation Mode	Continuous
RX/TX Channel	700
AGC	14
Input Power	-60dBm
Input Frequency	1842.86771MHz
Probed Power	Pref - 2.0dB

<b>Testpoint</b>	<b>Rx 1</b>
Band	GSM850/900
Active Unit	RX
Operation Mode	Continuous
RX/TX Channel	37
AGC	14
Input Power	-60dBm
Input Frequency	942.46771MHz
Probed Power	Pref - 1.5.0dB

<b>Testpoint</b>	<b>ANT (Antenna Feed)</b>
Band	GSM900
Active Unit	RX
Operation Mode	Continuous
RX/TX Channel	37
AGC	14
Input Power	-60dBm
Input Frequency	942.46771MHz
Probed Power	Pref (dBm) typ. - 63dBm
DC Level	0V

Layout: 19ga\_41a

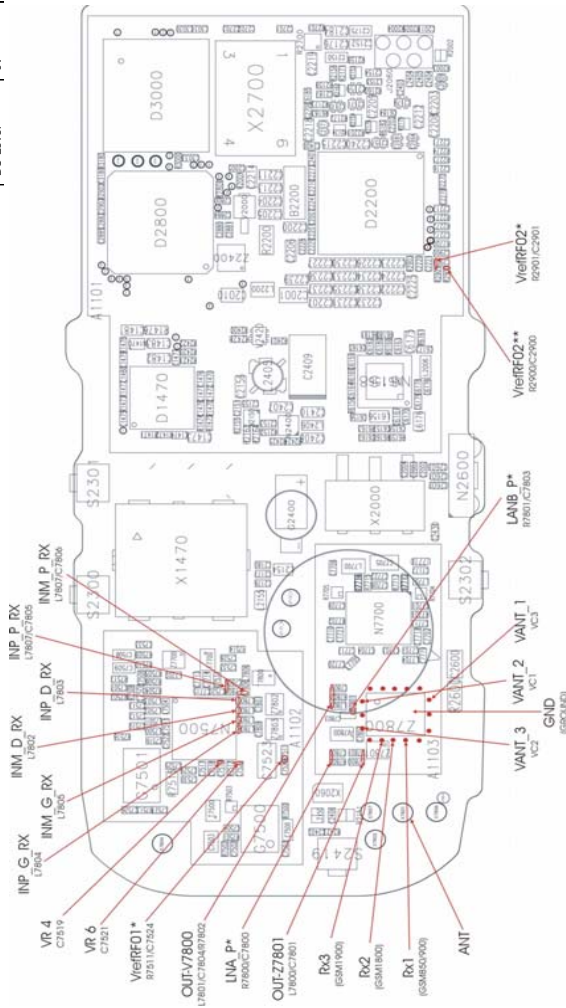

<b>Testpoint</b>	<b>VrefRF01*</b>
Band	GSM900
Active Unit	RX
Operation Mode	Continuous or Burst
RX/TX Channel	37
DC Level	1.35 V

<b>Testpoints</b>	<b>1) VrefRF02*</b> <b>2) VrefRF02**</b>
Band	GSM900
Active Unit	RX
Operation Mode	Continuous or Burst
RX/TX Channel	37
DC Level	1.35 V

<b>Testpoint</b>	<b>OUT-Z7801</b>
Band	GSM1900
Active Unit	RX
Operation Mode	Continuous
RX/TX Channel	661
AGC	14
Input Power	-60dBm
Input Frequency	1960.06771MHz
Probed Power	Pref - 3.5dB

<b>Testpoint</b>	<b>OUT-V7800</b>
Band	GSM1900
Active Unit	RX
Operation Mode	Continuous
RX/TX Channel	661
AGC	14
Input Power	-60dBm
Input Frequency	1960.06771MHz
Probed Power	Pref + 14dB

<b>Testpoints</b>	<b>1) INP_P_RX</b> <b>2) INM_P_RX</b>
Band	GSM1900
Active Unit	RX
Operation Mode	Continuous
RX/TX Channel	661
AGC	14
Input Power	-60dBm
Input Frequency	1960.06771MHz
Probed Power	Pref - 6.5 dB
DC Level	1.6V

<b>Testpoints</b>	<b>1) INP_D_RX</b> <b>2) INM_D_RX</b>
Band	GSM1800
Active Unit	RX
Operation Mode	Continuous
RX/TX Channel	700
AGC	14
Input Power	-60dBm
Input Frequency	1842.86771MHz
Probed Power	Pref - 6dB
DC Level	Typ. 1.6V

<b>Testpoints</b>	<b>1) INP_G_RX</b> <b>2) INM_G_RX</b>
Band	GSM900
Active Unit	RX
Operation Mode	Continuous
RX/TX Channel	37
AGC	14
Input Power	-60dBm
Input Frequency	942.46771MHz
Probed Power	Pref - 3.5dB
DC Level	Typ. 1.6V

<b>Testpoint</b>	<b>VANT_1_2_3</b>
Band	GSM900
Active Unit	RX [TX]
Operation Mode	Continuous
RX/TX Channel	37
Testpoints	<b>VANT_1</b> (VC3) <b>VANT_2</b> (VC3) <b>VANT_3</b> (VC3)
DC Level	0V [2.6V] 0V [0V] 0V [2.6V]

<b>Testpoint</b>	<b>VANT_1_2_3</b>
Band	GSM1800
Active Unit	RX [TX]
Operation Mode	Continuous
RX/TX Channel	700
Testpoints	<b>VANT_1</b> (VC3) <b>VANT_2</b> (VC3) <b>VANT_3</b> (VC3)
DC Level	0V [2.6V] 0V [2.6V] 0V [2.6V]

<b>Testpoint</b>	<b>VANT_1_2_3</b>
Band	GSM1900
Active Unit	RX [TX]
Operation Mode	Continuous
RX/TX Channel	661
Testpoints	<b>VANT_1</b> (VC3) <b>VANT_2</b> (VC3) <b>VANT_3</b> (VC3)
DC Level	0V [2.6V] 0V [2.6V] 2.5V [2.5V]

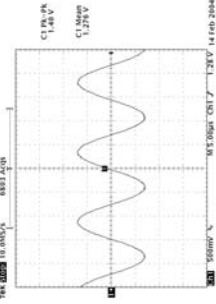
<b>Testpoints</b>	1) RXI 2) RXQ
Band	GSM900 or GSM1800 or GSM1900
Active Unit	RX
Operation Mode	Continuous
RX/TX Channel	37 or 700 or 661
AGC	10
Input Power	-60dBm
Input Frequency	942.46771, 1842.86771 or 1960.06771MHz
Signal Amplitude	1.4Vpp
DC Offset	1.28Vdc
Frequency	67kHz
Graph	

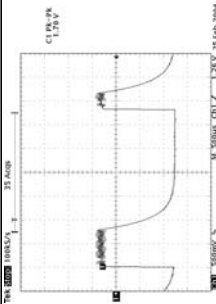
<b>Testpoints</b>	1) CM_F_I 2) CM_F_Q
Band	GSM900 or GSM1800 or GSM1900
Active Unit	RX
Operation Mode	Burst
RX/TX Channel	37 or 700 or 661
AGC	10
Input Power	-60dBm
Input Frequency	942.46771, 1842.86771 or 1960.06771MHz
Signal Amplitude	Approx. 1.75 Vpp
Graph	

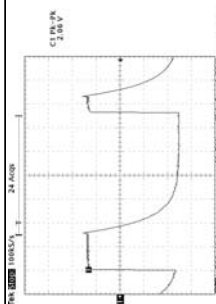
<b>Testpoints</b>	1) CM_DTOS_I 2) CM_DTOS_Q
Band	GSM900 or GSM1800 or GSM1900
Active Unit	RX
Operation Mode	Burst
RX/TX Channel	37 or 700 or 661
AGC	14
Input Power	-60dBm
Input Frequency	942.46771, 1842.86771 or 1960.06771MHz
Signal Amplitude	Approx. 2 Vpp
Graph	

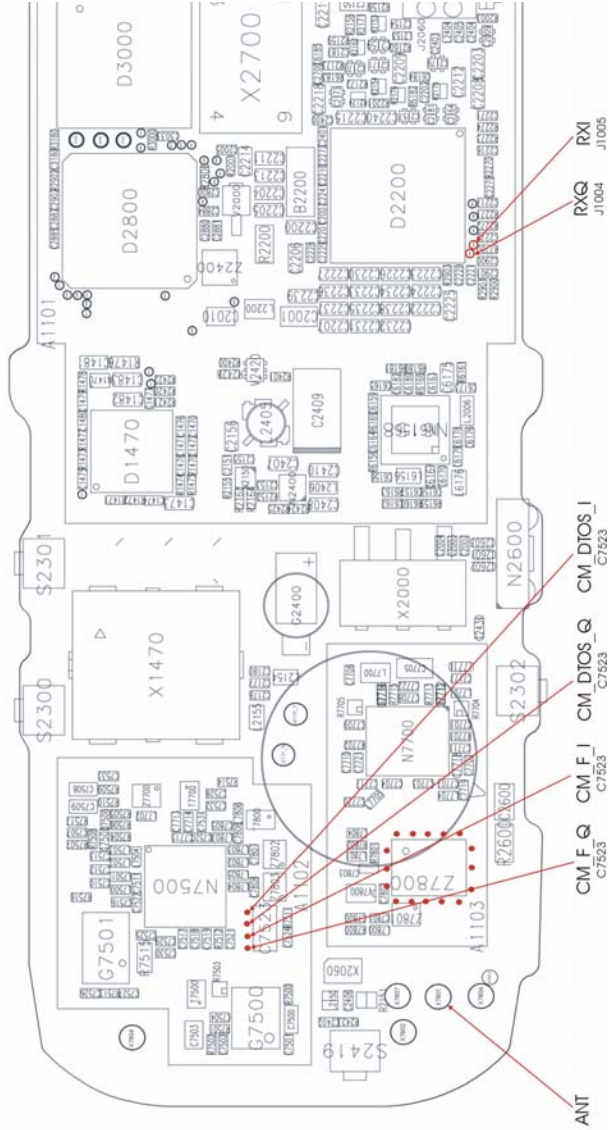

**Transmitter test points**

Modulation		GMSK (EDGE = OFF)		G-PSK (EDGE = ON)	
Band	GSM 850 or 900 or 1800 or 1900	Band	GSM 850 or 900 or 1800 or 1900	Band	GSM 850 or 900 or 1800 or 1900
Active Unit	TX	Active Unit	TX	Active Unit	TX
Operation Mode	Burst	Operation Mode	Burst	Operation Mode	Burst
Test point	TXC	Test point	TXC	Test point	TXC
Graph					
Test point	VTXB_900	Test point	VTXB_900	Test point	VRF01_900
Graph					
Test point	VRF01_900	Test point	VRF01_900	Test point	VRF01_900
Graph					
Test point	YDET	Test point	YDET	Test point	YDET
Graph					

VREF01		VR3	
Band	GSM900	Band	GSM900
Active Unit	TX	Active Unit	TX
Operation Mode	Burst	Operation Mode	Burst
RX/TX Channel	37	RX/TX Channel	37
DC Level	1.35V	DC Level	2.8V

Testpoints	
TXP (R737)	TXM (R735)
TXM (R737)	TXQ (R735)
TXM (R737)	TXQ (R735)
Band	GSM 850 or 900 or GSM1800 or GSM1900
Active Unit	TX
Operation Mode	Burst
RX/TX Channel	180 or 37 or 700 or 661
Tx Data Type	Random
Tx Power Level	any
Signal Amplitude	520mVpp
DC Offset	1.2Vdc
Graph	

Transmitter Test Points (1/3)

Matrix Antenna Switch Module Z7800					
Test points: RFin_900 and RFin_1800/1900					
VANT_2	VANT_3	VANT_1	Rc1	Rc2	Rc3
[Voh]	[Voh]	[Voh]	GSM 850	GSM 1800	GSM 1900
0	0	0	Rx	Rx	Tx
0	0	0	X	X	X
0	0	0	0	0	0
2.8	2.8	2.8	0	0	0

VBAT		VR2 (C7812)	
Band	GSM900	Band	GSM900/1800/1900
Active Unit	TX	Active Unit	TX
Operation Mode	Burst	Operation Mode	Burst
RX/TX Channel	37	RX/TX Channel	37
DC Level	Typ. 3.6V	DC Level	2.8V

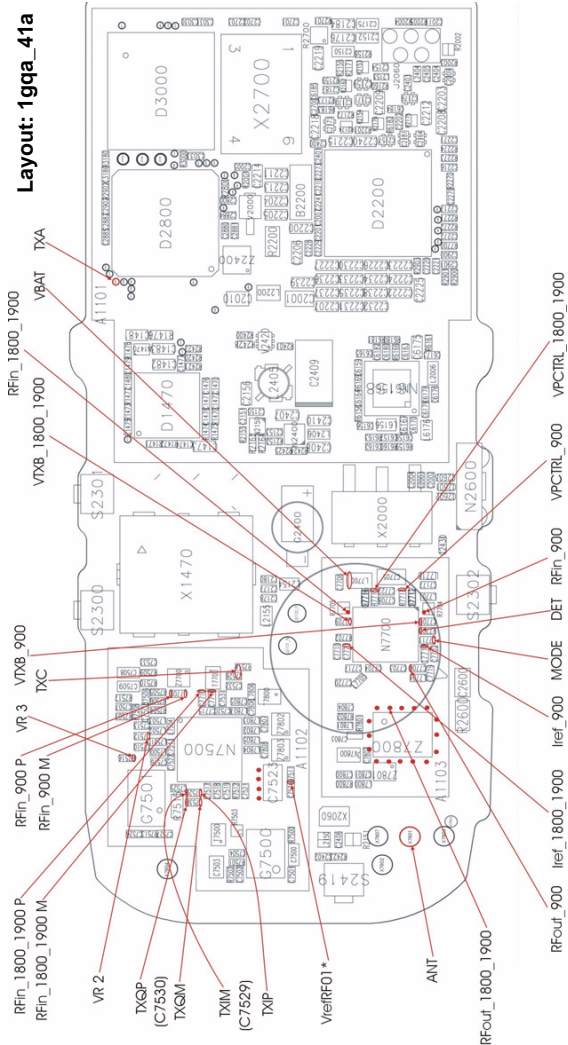









■ **Synthesizer test points**

<b>Testpoint</b>	<b>VR3</b>	<b>VR5</b>	<b>VR7</b>
Band	default (GSM850 or GSM850)		
Active Unit	Rx		
Operation Mode	Burst or Continuous		
RX/TX Channel	default		
DC Level	2.78V	2.78V	2.78V

<b>Testpoint</b>	<b>VR1</b>	<b>VrefRF01</b>	<b>VrefRF02</b>
Band	default (GSM850 or GSM850)		
Active Unit	Rx		
Operation Mode	Burst or Continuous		
RX/TX Channel	default		
DC Level	4.76	1.35V	1.35V

<b>Testpoint</b>	<b>AFC (Vc of VCTCXO)</b>
Band	default
Active Unit	RX
Operation Mode	Continuous
RX/TX Channel	any
AFC (value)	-1024 150 1023
AFC voltage	0.1V 1.4V 2.5V

<b>Testpoint</b>	<b>Vc of VCO</b>
Band	GSM1800 GSM1900 GSM1900
Active Unit	TX TX TX
Operation Mode	Continuous
RX/TX Channel	512 512 810
Frequency	3420.4MHz 3700.4MHz 3879.6MHz
DC Level	-1.3V -2.5V -3.6V
Note	Take care to select the highest PCL 15 if activating TX Continuous mode, otherwise the power amplifier will be destroyed.

<b>Testpoint</b>	<b>VCOout</b>
Band	GSM1800 GSM1900 GSM1900
Active Unit	TX TX TX
Operation Mode	Continuous
RX/TX Channel	512 512 810
Frequency	3420.4MHz 3700.4MHz 3879.6MHz
Level (spec. range = -3.5...+2.5dBm)	-10dBm ~ -10dBm ~ -10dBm
Notes	Measured using the special probe with capacitive coupling. No exact power measurement possible.  Take care to select the highest PCL 15 if activating TX Continuous mode, otherwise the power amplifier will be destroyed.

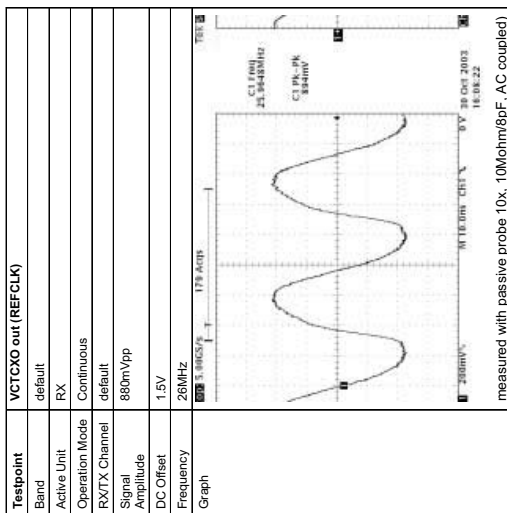
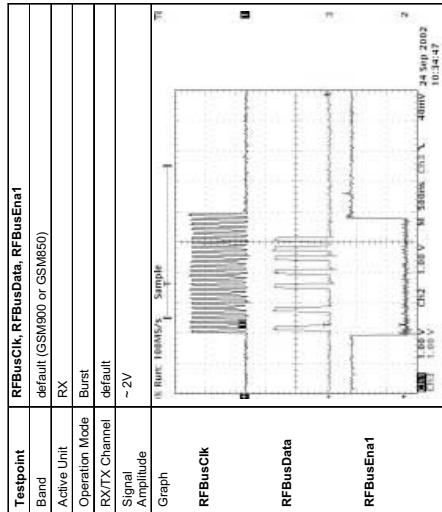

Layout: 19qa\_41a

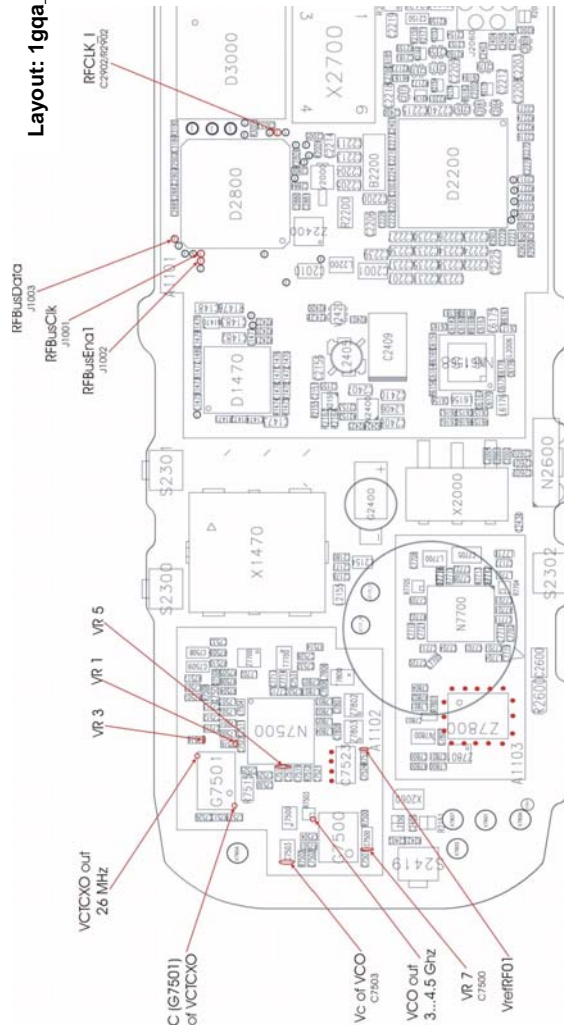

This page has been intentionally left blank.